

APMT APMT 玉米型粗铣刀	AP AP 玉米型粗铣刀	D52 APMT 玉米型粗铣刀	D52 APMT 玉米型粗铣刀	LPMT LPMT 玉米型粗铣刀	SPMT SPMT 玉米型粗铣刀	SPM SPM 玉米型粗铣刀	SPC SPC 玉米型粗铣刀	SPC SPC 玉米型粗铣刀	HMP10 HMP10 玉米型粗铣刀	HMP01 HMP01 玉米型粗铣刀
-------------------------------	---------------------------	------------------------------	------------------------------	-------------------------------	-------------------------------	-----------------------------	-----------------------------	-----------------------------	---------------------------------	---------------------------------



ZC... ZC... 球头精铣刀	BCF BCF 球头精铣刀	SWB... SWB... 球头精铣刀	SWB SWB 球头精铣刀	ZPFG... ZPFG... 球头精铣刀	ABPF ABPF 球头精铣刀	ABPF ABPF 球头精铣刀	ZCFW... ZCFW... 球头精铣刀	ARPF ARPF 球头精铣刀	BNM... BNM... 球头精铣刀
--------------------------------	----------------------------	----------------------------------	----------------------------	------------------------------------	------------------------------	------------------------------	------------------------------------	------------------------------	----------------------------------



ADI/AP... ADI/AP... 钻铣共用立铣刀	ASJ ASJ 钻铣共用立铣刀	CC/GP... CC/GP... 钻铣共用立铣刀	CH CH 钻铣共用立铣刀	TJU TJU 钻铣共用立铣刀
------------------------------------------	------------------------------	----------------------------------------	----------------------------	------------------------------



TCMX TCMX 倒角刀	SSP SSP 倒角刀	TP TP 倒角刀	TP TP 倒角刀
----------------------------	--------------------------	------------------------	------------------------

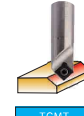

TGF/TT43... TGF/TT43... 三面刃铣刀	D55 D55 三面刃铣刀	SMT SMT 三面刃铣刀	SMT SMT 三面刃铣刀	SMT SMT 三面刃铣刀
--------------------------------------------	----------------------------	----------------------------	----------------------------	----------------------------

- 刀杆刀盘
- 直角台肩立铣刀
- 圆角铣刀
- 球头铣刀
- 钻铣刀杆
- 倒角刀杆
- 玉米铣刀
- 三面刃槽刀
- 快进给系列
- 龙门平面铣刀
- 锁牙式刀柄

- 刀杆刀盘
- 直角台肩立铣刀
- 圆角铣刀
- 球头铣刀
- 钻铣刀杆
- 倒角刀杆
- 玉米铣刀
- 三面刃槽刀
- 快进给系列
- 龙门平面铣刀
- 锁牙式刀柄

3PTE... 3PTE... 直角台肩立铣刀	JDMT JDMT 直角台肩立铣刀	AHU AHU 直角台肩立铣刀	AHUB AHUB 直角台肩立铣刀	AHUM AHUM 直角台肩立铣刀	JDMT07... JDMT07... 直角台肩立铣刀	ASM ASM 直角台肩立铣刀	ASMM ASMM 直角台肩立铣刀	APKT... APKT... 直角台肩立铣刀	AP1003... AP1003... 直角台肩立铣刀	BT...AP10... BT...AP10... 直角台肩立铣刀	AP1003... AP1003... 直角台肩立铣刀
--------------------------------------	--------------------------------	------------------------------	--------------------------------	--------------------------------	------------------------------------------	------------------------------	--------------------------------	--------------------------------------	------------------------------------------	------------------------------------------------	------------------------------------------

TCMT TCMT 三面刃铣刀	SSO SSO 三面刃铣刀	SSY SSY 三面刃铣刀	TCM TCM 三面刃铣刀	SSH SSH 三面刃铣刀
------------------------------	----------------------------	----------------------------	----------------------------	----------------------------

SPMG SPMG 三面刃铣刀	SMP SMP 三面刃铣刀	SMP SMP 三面刃铣刀	XSEQ XSEQ 三面刃铣刀	SMP10 SMP10 三面刃铣刀	SMP10 SMP10 三面刃铣刀
------------------------------	----------------------------	----------------------------	------------------------------	--------------------------------	--------------------------------

高进给铣刀 High feed milling cutter	双面 HNGX HNGX 高进给铣刀	KSHR KSHR 高进给铣刀
------------------------------------------	---------------------------------	------------------------------

双面 BLMP BLMP 高进给铣刀	TEBL TEBL 高进给铣刀	TEBL TEBL 高进给铣刀	双面 LMMU LMMU 高进给铣刀	EXN03 EXN03 高进给铣刀	EXN03 EXN03 高进给铣刀
---------------------------------	------------------------------	------------------------------	---------------------------------	--------------------------------	--------------------------------

WNMU 平面高进给 双面有孔 铣削刀片

刀片(Insert):
WNMU0404 ZP153
Ap:0.6-3.0 (mm)
Fz:0.08-0.60 (mm/rev)
Vc:100-260 (m/min)

切削形态: 稳定切削, 一般切削, 不稳定切削

P 钢	Steel
M 不锈钢	Stainless Steel
K 铸铁	Iron
N 铝/铜/镁/锌/塑料/木材	Aluminum/Copper/Magnesium/Zinc/Plastic/Wood
S 硬质合金/粉末冶金	Carbide/Powder Metallurgy
H 钛/高温合金/碳纤维	Titanium/Superalloy/Carbon Fiber

用途: 产品图片, 几何尺寸, 规格型号, 尺寸 Dimension (mm), 配套刀柄

刀柄: D03

WNMU 平面高进给 双面有孔 铣削刀片

刀片(Insert):
WNMU0806 ZP153
Ap:0.6-8.0 (mm)
Fz:0.08-0.60 (mm/rev)
Vc:100-260 (m/min)

切削形态: 稳定切削, 一般切削, 不稳定切削

P 钢	Steel
M 不锈钢	Stainless Steel
K 铸铁	Iron
N 铝/铜/镁/锌/塑料/木材	Aluminum/Copper/Magnesium/Zinc/Plastic/Wood
S 硬质合金/粉末冶金	Carbide/Powder Metallurgy
H 钛/高温合金/碳纤维	Titanium/Superalloy/Carbon Fiber

用途: 产品图片, 几何尺寸, 规格型号, 尺寸 Dimension (mm), 配套刀柄

刀柄: D04

R217.96 机夹式快进给立铣刀-双面六角刀片
Clip-Type Fast Feed End Milling Cutter
-Double-Sided Hexagonal Insert

切削参数 (Cutting Parameters): R15-R18
零配件 (Spare Parts): P01-P04

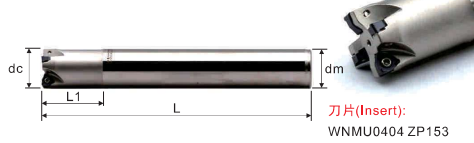

刀片(Insert):
WNMU0404 ZP153
Ap:0.6-3.0 (mm)
Fz:0.08-0.60 (mm/rev)
Vc:100-260 (m/min)

● 特点: 高进给, 高效率
★ Characteristic: High Feed, High Efficiency

订购编号	规格型号	尺寸 Dimensions			刃数	价格
Order Number	Specification	dc	dm	L	Edge	Price
337200	R217.96-2020-04-3A	20	20	30	3	800
337202	R217.96-2021-04-3A	21	20	30	3	820
337204	R217.96-2525-04-4A	25	25	60	4	950
337206	R217.96-2526-04-4A	26	25	35	4	1020
337208	R217.96-3230-04-5A	30	32	70	5	1750
337210	R217.96-3232-04-5A	32	32	70	5	1900
337212	R217.96-3235-04-5A	35	32	35	200	2000

R217.96 机夹式快进给立铣刀刀盘-双面六角刀片
Clip-Type Fast Feed End Milling Cutter Head
-Double-Sided Hexagonal Insert

切削参数 (Cutting Parameters): R15-R18
零配件 (Spare Parts): P01-P04

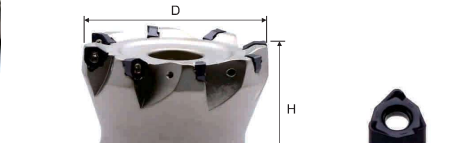

刀片(Insert):
WNMU0404 ZP153
Ap:0.6-3.0 (mm)
Fz:0.08-0.60 (mm/rev)
Vc:100-260 (m/min)

● 特点: 高进给, 高效率
★ Characteristic: High Feed, High Efficiency

订购编号	规格型号	尺寸 Dimensions			刃数	价格
Order Number	Specification	D	d	H	Edge	Price
337220	R217.96-0040-04-6A	40	16	40	6	1100
337222	R217.96-0050-04-6A	50	22	45	6	1350
337226	R217.96-0063-04-8A	63	22	45	8	1550

MFWN 机夹式快进给立铣刀-双面六角刀片
Clip-Type Fast Feed End Milling Cutter-Double-Sided Hexagonal Insert

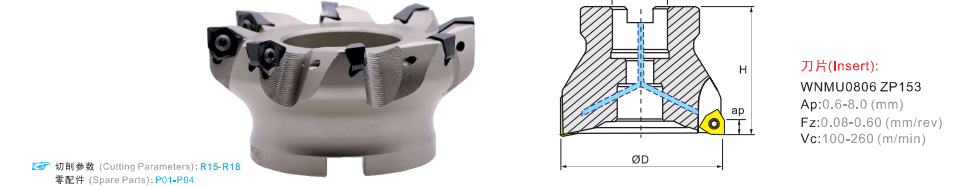

切削参数 (Cutting Parameters): R15-R18
零配件 (Spare Parts): P01-P04

规格型号	尺寸 Dimensions (mm)			刃数 Edges	重量 (kg)	刀片 Insert	螺钉 Screw	扳手 Wrench	库存 Stock	编码 Code	Price (RMB)
	D	d	H								
MFWN 90050R-3T-M	50	22	50	3	0.4	WNMU0806..	M5.0×14	T20	●	337230	857
90063R-3T-M	63	22	50	3	0.5				●	337232	1000
90063R-4T-M	63	22	50	4	0.5				●	337234	1050
90063R-5T-M	63	22	50	5	0.5				●	337236	1050
90080R-4T-M	80	27	50	4	1.0				●	337238	1200
90080R-5T-M	80	27	50	5	1.0				●	337240	1283
90080R-7T-M	80	27	50	7	1.1				●	337242	1867
90100R-5T-M	100	32	50	5	1.3				●	337244	1900
90100R-7T-M	100	32	50	7	1.3				●	337246	1983
90100R-9T-M	100	32	50	9	1.3				●	337248	2567
90125R-6T-M	125	40	63	6	2.5				●	337250	2300
90125R-8T-M	125	40	63	8	2.6				●	337252	2333
90125R-12T-M	125	40	63	12	2.6				●	337254	3267
90160R-8T-M	160	40	63	8	3.8				●	337256	3100
90160R-10T-M	160	40	63	10	3.9				●	337258	3150
90160R-14T-M	160	40	63	14	3.9				●	337260	4317
90200R-10T-M	200	60	63	10	6.0				●	337262	4300
90200R-12T-M	200	60	63	12	6.3				●	337264	4387
90200R-16T-M	200	60	63	16	6.4				●	337266	5787
90250R-12T-M	250	60	63	12	8.4				●	337268	7300
90250R-14T-M	250	60	63	14	8.7	●	337270	7350			
90250R-18T-M	250	60	63	18	8.8	●	337272	9217			

JDMT 直角台肩 有孔 铣削刀片

用途 Application	产品图片 Product Image	几何尺寸 Dimensioning	规格型号 Specification	尺寸 Dimension (mm)						配磨刀柄 Matching Toolholder
				r _φ	A	B	T	a	φD	
直角台肩 有孔 铣削刀片			JDMT 07020R 070204R 070208R EDMT 070220R-T 070220R	0.2	6.4	4.3	2.45		6	D11
				0.4	6.4	4.3	2.45		6	
				0.8	6.4	4.3	2.45		6	
				2.0	6.4	4.3	2.5		6	
				2.0	6.4	4.3	2.5		6	
				2.0	6.4	4.3	2.5		6	

APKT 直角台肩 有孔 铣削刀片

用途 Application	产品图片 Product Image	几何尺寸 Dimensioning	规格型号 Specification	尺寸 Dimension (mm)				配磨刀柄 Matching Toolholder
				r _φ	A	B	T	
直角台肩 有孔 铣削刀片			APKT 1003PDR-HM 1003PDR-76 1003PDR-RM 10038PDR-RM 100310PDR-RM 100312TR-RM 100316PDR-RM 100320PDR-RM	0.5	10.95	6.7	3.55	D12
				0.5	11.00	6.7	3.47	
				0.5	11.00	6.7	3.47	
				0.8	11.00	6.7	3.47	
				1.0	10.75	6.7	3.47	
				1.2	10.50	6.7	3.47	
1.6	10.90	6.7	3.47	D12				
2.0	10.90	6.7	3.47					

刀杆
刀盘

直角
台肩
立
铣刀

圆角
铣刀

球头
铣刀

钻头
刀杆

倒角
刀杆

玉米
铣刀

三面
刃
槽刀

快
进
给
系列

龙门
平面
铣刀

锁
牙
式
刀柄

ASM 直角台肩精铣刀 Right angle shoulder fine milling cutter

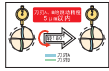

切削参数 (Cutting Parameters): R15-R18
零配件 (Spare Parts): P01-P04

- 适合强力切削，回转及进刀量是一般铣刀的3倍
- 刃口锋利，坚固。

- ★ Suitable for heavy cutting, rotary and feed volume is 3 times the normal cutter.
- ★ Blade sharp, strong.

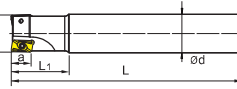

AP1003 直角台肩铣刀 Right Angle Shoulder Milling Cutter

切削参数 (Cutting Parameters): R15-R18
零配件 (Spare Parts): P01-P04

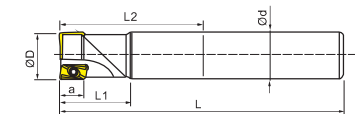

- 适合强力切削，回转及进刀量是一般铣刀的3倍
- 刃口锋利，坚固。

- ★ Suitable for heavy cutting, rotary and feed volume is 3 times the normal cutter.
- ★ Blade sharp, strong.

型号 Cat. No	尺寸 Size				刃数 No. of Flutes	a	刀片 Insert	螺钉 Screw	扳手 Wrench	Stock	Order Number	Price (RMB)
	D	d	L	L1								
AP1003R16-16-100-2T	16	16	100	30	2	9	APKT1003..	M2.5×6	T8	o	323600	180
AP1003R16-16-150-2T	16	16	150	30	2					o	323602	180
AP1003R20-18-150-2T	18	20	150	30	2					o	323604	200
AP1003R20-18-200-2T	18	20	200	30	2					o	323606	200
AP1003R20-20-100-2T	20	20	100	30	2					o	323608	200
AP1003R20-20-150-2T	20	20	150	30	2					o	323610	200

AP10一体式高速强力方肩铣刀

AP10 integrated high strength square shoulder milling cutter

切削参数 (Cutting Parameters): R15-R18
零配件 (Spare Parts): P01-P04



型号 Cat. No	刃数 Edges	总长 L	有效长 L1	直径 D	刀片 Insert	Order Number	Price (RMB)
BT30-AP10-16-2T	2	155	90	16	APKT1003	323700	950
BT30-AP10-20-2T	2	155	90	20		323702	950
BT30-AP10-25-3T	3	155	90	25		323704	1000
BT30-AP10-32-4T	4	155	90	32		323706	1150
BT40-AP10-16-2T	2	155	90	16	APKT1003	323710	1000
BT40-AP10-20-2T	2	155	90	20		323712	1000
BT40-AP10-25-3T	3	155	90	25		323714	1150
BT40-AP10-32-4T	4	155	90	32		323716	1250

AP 直角台肩面铣刀盘 AP Right angle shoulder face mill

AP Right angle shoulder face mill

切削参数 (Cutting Parameters): R15-R18
零配件 (Spare Parts): P01-P04

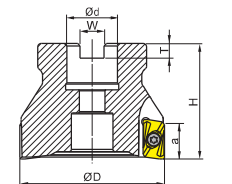

型号 Cat. No	刃数 No. of flutes	尺寸 Size				刀片 Insert	螺钉 Screw	扳手 Wrench	Stock	Order Number	Price (RMB)
		D	d	H	W						
AP1003R40-16-5T	5	40	16	40	10.4	APKT1003 APKX1003	M2.5×6	T8	o	323800	420
AP1003R50-22-6T	6	50	22	45	10.4				o	323802	380
AP1003R63-22-7T	7	63	22	45	10.4				o	323804	420

R390 直角台肩有孔铣削刀片

用途 Product Image	几何尺寸 Dimensioning	规格型号 Specification	尺寸 Dimension (mm)				配套刀柄 Matching Toolholder	刀片 (Toolholder)
			FC	A	B	T		
		R390-11T304M-PM	0.4	10	6.8	3.59		
		11T308M-PM	0.8	10	6.8	3.59		
		11T316M-PM	1.6	10	6.8	3.59		
		11T331M-PM	3.1	10	6.8	3.59		
		170404M-PM	0.4	15.7	9.6	4.76		
		170408M-PM	0.8	15.7	9.6	4.76		
		170416M-PM	1.6	15.7	9.6	4.76		
		170431M-PM	3.1	15.7	9.6	4.76		

R390 直角台肩精铣刀
Right angle shoulder fine milling cutter

切削参数 (Cutting Parameters): R15-R18
零配件 (Spare Parts): P01-P04

- 精度高, 适于精加工
- High precision, suitable for finishing

型号 Cat. No	尺寸 Size					刀片 Insert	螺钉 Screw	扳手 Wrench	Stock	Order Number	Price (RMB)	Price (RMB)			
	D	d	L	L1	a										
R390-11R15-16-150-2T	16	15	150	40	11	R390-11T308	M2.5x6	T8	●	324600	133	350			
R390-11R15-16-200-2T	16	15	200	40	11				●	324602	167	-			
R390-11R16-16-150-2T	16	16	150	50	11				●	324604	133	150			
R390-11R16-16-200-2T	16	16	200	60	11				●	324606	167	160			
R390-11R16-17-150-2T	17	16	150	40	11				●	324608	133	170			
R390-11R16-17-200-2T	17	16	200	40	11				●	324610	167	180			
R390-11R19-20-150-2T	20	19	150	40	11				●	324612	150	-			
R390-11R19-20-200-2T	20	19	200	40	11				●	324614	183	200/380			
R390-11R20-20-150-2T	20	20	150	50	11				●	324616	150	180			
R390-11R20-20-200-2T	20	20	200	60	11				●	324618	183	200			
R390-11R20-21-150-2T	21	20	150	50	11				●	324620	150	180			
R390-11R20-21-200-2T	21	20	200	50	11				●	324622	183	200			
R390-11R20-22-200-2T	22	20	200	50	11				●	324624	-	360			
R390-11R24-25-150-2T	25	24	150	50	11				●	324626	167	-			
R390-11R24-25-200-2T	25	24	200	50	11				●	324628	200	-			
R390-11R24-25-220-2T	25	24	220	50	11				●	324630	-	450			
R390-11R25-25-150-2T	25	25	150	50	11				●	324632	167	225			
R390-11R25-25-200-2T	25	25	200	60	11				●	324634	200	250			
R390-11R25-26-150-2T	26	25	150	50	11				●	324636	167	225			
R390-11R25-26-200-2T	26	25	200	60	11				●	324638	200	250			
R390-11R25-26-250-2T	26	25	250	60	11				●	324640	233	-			
R390-11R29-30-250-2T	30	29	250	50	11				●	324642	-	640			
R390-11R32-33-150-2T	33	32	150	50	11				●	324644	200	-			
R390-11R32-33-200-2T	33	32	200	50	11				●	324646	233	-			
R390-11R32-33-250-2T	33	32	250	50	11				●	324648	267	-			
R390-11R32-33-300-2T	33	32	300	50	11				●	324650	300	-			
R390-11R32-33-350-2T	33	32	350	50	11				●	324652	333	-			
R390-11R32-35-330-2T	35	32	330	55	11				●	324654	-	750			
R390-17R25-25-160-2T	25	25	160	40	17				R390-170408	M3.5x8	T15	●	324656	-	225
R390-17R25-25-200-2T	25	25	200	50	17							●	324658	-	250
R390-17R25-32-200-2T	32	25	200	50	17	●	324660	-				300			

R390 直角台肩面铣刀盘
Right Angle Shoulder Milling Cutter

- 适配精磨刀片
- 精度高, 适于精加工
- 锥形设计, 钢性高
- Adapter grinding Inserts
- High precision, suitable for finishing
- Cone design, steel high

切削参数 (Cutting Parameters): R15-R18
零配件 (Spare Parts): P01-P04

型号 Cat. No	尺寸 Size					刀片 Insert	螺钉 Screw	扳手 Wrench	Stock	Order Number	Price (RMB)
	D	d	H	W	T						
R390-11R50-22-4T	50	22	50	10.4	6.3	R390-11T308	M2.5x6	T8	●	324500	240/400
R390-11R63-22-4T	63	22	50	10.4	6.3				●	324502	280/500
R390-17R63-22-4T	63	22	50	10.4	6.3				●	324504	250
R390-17R80-27-6T	80	27	50	12.4	7	R390-170408	M3.5x10	T15	●	324506	400
R390-17R100-32-6T	100	32	50	14.4	8				●	324508	600
R390-17R125-40-6T	125	40	63	16.4	9				●	324510	750
R390-17R160-80-6T	160	40	63	16.4	9				●	324512	1150

R390 锁牙式刀头
R390 Shoulder/Cutting End Mills

切削参数 (Cutting Parameters): R15-R18
零配件 (Spare Parts): P01-P04

型号 Cat. No	尺寸 Size				Teeth	刀片 Insert	压板 Clamp	螺钉 Screw	扳手 Wrench	Stock	Order Number	Price (RMB)
	D	L	d	M								
R390-11-16-2T-M8	16	25	8.5	M8	2	R390-11T308	-	M2.5X6	T8	●	324530	250
R390-11-17-2T-M8	17	25	8.5	M8	2					●	324532	250
R390-11-20-2T-M10	20	30	10.5	M10	2					●	324534	300
R390-11-21-2T-M10	21	30	10.5	M10	2					●	324536	300
R390-11-25-2T-M12	25	35	12.5	M12	2					●	324538	400
R390-11-26-2T-M12	26	35	12.5	M12	2					●	324540	400
R390-11-32-2T-M16	32	35	17	M16	2					●	324542	500
R390-11-33-2T-M16	33	35	17	M16	2					●	324544	500
R390-11-35-3T-M16	35	40	17	M16	3					●	324546	500

R390 一体式高速强力方肩铣刀
R390 Integrated High Strength Square Shoulder Milling Cutter

- 一体式刚性结构, 轻量化, 更高刚性性能。
- 通过选用不同材料刀粒, 可用于钢及铝合金的精加工, 适用范围广, 高效率, 高刚性!
- Lightweight one-piece rigid structure, high performance, more.
- Through the selection of different material grain, can be used in the steel and copper/aluminum alloy. The coarse and fine processing, wide application range, high efficiency, high rigidity!

切削参数 (Cutting Parameters): R15-R18
零配件 (Spare Parts): P01-P04

型号 Cat. No	刃数 Edges	总长 L	有效长 L1	直径 D	刀片 Insert	Stock	Order Number	Price (RMB)
BT30-R390-16-2T	2	155	35	16	R390-11T308	●	324700	1150
BT30-R390-20-2T	2	155	35	20		●	324702	1150
BT30-R390-25-3T	3	155	35	25		●	324704	1100
BT30-R390-32-4T	4	155	35	32		●	324706	1200
BT40-R390-16-2T	2	155	45	16		●	324708	1100
BT40-R390-20-2T	2	155	45	20		●	324710	1100
BT40-R390-25-3T	3	155	45	25		●	324712	1250
BT40-R390-32-4T	4	155	45	32		●	324714	1350

APNT
ADNT

直角台肩
有孔
铣削刀片

Table with columns: 用途, 产品图片, 几何尺寸, 规格型号, 尺寸 Dimension (mm), 配套刀柄, 刀片. Lists various APNT and ADNT models with their specifications.

UEX 直角台肩精铣刀

Right Angle Shoulder Fine Milling Cutter

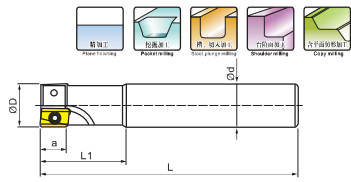

切削参数 (Cutting Parameters): R15-R18
零配件 (Spare Parts): P01-P04

Main table for UEX tools listing models (型号), sizes (尺寸), inserts, screws, wrenches, stock status, order numbers, and prices.

EDC10 一体式高速强力方肩铣刀

EDC10 Integrated High Strength Square Shoulder Milling Cutter



- 一体式刚性结构, 轻量化, 更具高速性能。
• 通过选用不同材质刀粒, 可适用于钢及铜铝合金的粗精加工, 适用范围广, 高效率, 高刚性!

- ★ Lightweight one-piece rigid structure, high performance, more.
★ Through the selection of different material grain, can be used in the steel and copper aluminum alloy The coarse and fine processing, wide application range, high efficiency, high rigidity!

Table listing EDC10 models with columns for blade number, length, diameter, insert, stock, order number, and price.

AXMT
有孔
铣削刀片

Table listing AXMT models with columns for 用途, 产品图片, 几何尺寸, 规格型号, 尺寸 Dimension (mm), 配套刀柄, 刀片. Includes diagrams for each model.

TE90 直角台肩精铣刀

Right Angle Shoulder Fine Milling Cutter

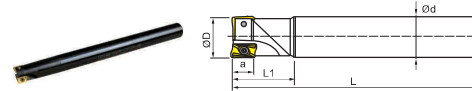

TE90 锁牙式铣刀头

Lock type milling head

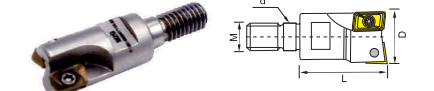

切削参数 (Cutting Parameters): R15-R18
零配件 (Spare Parts): P01-P04

Main table for TE90 tools listing models, sizes, inserts, screws, wrenches, stock status, order numbers, and prices.

Table listing additional TE90 models with columns for 型号, 尺寸 Size, Teeth, 刀片 Insert, 压板 Clamp, 螺钉 Screw, 扳手 Wrench, Stock, Order Number, Price.

刀杆
刀盘

直角
台肩
立
铣刀

圆角
铣刀

球头
铣刀

钻铣
刀杆

倒角
刀杆

玉米
铣刀

三面
刃槽刀

快
进给
系列

龙门
平面
铣刀

锁
牙式
刀柄

刀杆
刀盘

直角
台肩
立
铣刀

圆角
铣刀

球头
铣刀

钻铣
刀杆

倒角
刀杆

玉米
铣刀

三面
刃槽刀

快
进给
系列

龙门
平面
铣刀

锁
牙式
刀柄

RD.. 15°后角圆形
有孔单面
铣削刀片

Table with 2 columns: Material (P, M, K, N, S, H) and Steel/Aluminum/Carbon Fiber. Includes cutting conditions legend and material compatibility icons.

Main product specification table with columns: 用途, 产品图片, 几何尺寸, 规格型号, 尺寸, 配套刀柄. Includes diagrams of the cutter and its dimensions.

刀杆刀盘
直角台肩立铣刀
圆角铣刀
球头铣刀
钻铣刀杆
倒角刀杆
玉米铣刀
三面刃槽刀
快进给系列
龙门平面铣刀
锁牙式刀柄

TRS 圆鼻立铣刀
Round Nose End Mill



- 刀片经济, 适用性高
容屑空间大, 排屑好

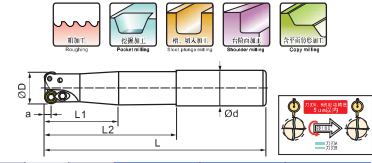

切削参数 (Cutting Parameters): R22-R24
零件图 (Spare Parts): P01-P04
Blade economy, the high applicability.
Deposity ship a large apesse, good chip removal.

Large table listing TRS Round Nose End Mill models, dimensions (D, d, L, L1, L2, a), tool inserts, and prices in RMB.

刀杆刀盘
直角台肩立铣刀
圆角铣刀
球头铣刀
钻铣刀杆
倒角刀杆
玉米铣刀
三面刃槽刀
快进给系列
龙门平面铣刀
锁牙式刀柄

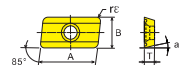
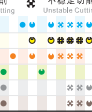

ADNT

倒角加工
有孔
铣削刀片

用途 Product Image		几何尺寸 Dimensioning		规格型号 Specification		尺寸 Dimension (mm)		配套刀柄 Matching Toolholder		材料 Material	
				ADNT 160308SR		r _C 0,8 A 15,875 B 9,525 T 3,18 a 15°					

APMT

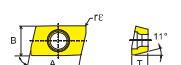
直角台肩
有孔
铣削刀片

用途 Product Image		几何尺寸 Dimensioning		规格型号 Specification		尺寸 Dimension (mm)				配套刀柄 Matching Toolholder		材料 Material	
				APKT 1135PDER-G2 1604PDER-G2		r _C 0,8 A 11 B 6,35 T 3,5 0,8 16,5 9,525 4,76							

刀杆刀盘

刀杆刀盘

直角台肩立铣刀

直角台肩立铣刀

圆角铣刀

圆角铣刀

球头铣刀

球头铣刀

钻铣刀杆

钻铣刀杆

倒角刀杆

倒角刀杆

玉米铣刀

玉米铣刀

三面刃槽刀

三面刃槽刀

快进给系列

快进给系列

龙门平面铣刀

龙门平面铣刀

锁牙式刀柄

锁牙式刀柄

SSK-45°

舍弃式倒角刀
SSK45° Discarding Chamfering

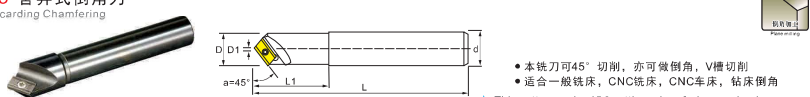



- 本铣刀可45° 切削, 亦可做倒角, V槽切削
- 适合一般铣床, CNC铣床, CNC车床, 钻床倒角
- ★ This cutter can be 45° cutting, chamfering can be done.
- ★ Suitable for general milling machine, integrated machining center.

型号 Cat. No	尺寸 Size						刃数 No. of flutes	倒角范围 Chamfering range	角度 Angle	刀片 Insert	螺钉 Screw	扳手 Wrench	Stock	Order Number	Price (RMB)
	D	d	D1	L1	L	a									
SSK-20-C20-130N	20	20	8	30	130	45°	1	Ø8~Ø20	45°	AD..1603..	M4x8	T15	●	333700	200

SPMW
SDMB

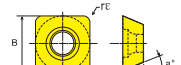
倒角加工
有孔
铣削刀片

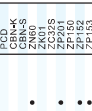
用途 Product Image		几何尺寸 Dimensioning		规格型号 Specification		尺寸 Dimension (mm)				配套刀柄 Matching Toolholder		材料 Material	
				SPMW 090304 SDMB 26152		r _C 0,4 A 9,525 B 9,525 T 3,18 0,4 8,3 8,3 2,5							

SB-45°

倒角刀
Chamfering

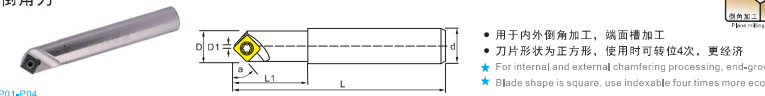

- 用于内外倒角加工, 端面槽加工
- 刀片形状为正方形, 使用时可换位4次, 更经济
- ★ For internal and external chamfering processing, end-groove.
- ★ Blade shape is square, use indexable four times more economical.

型号 Cat. No	尺寸 Size						刃数 No. of flutes	倒角范围 Chamfering range	角度 Angle	刀片 Insert	螺钉 Screw	扳手 Wrench	Stock	Order Number	Price (RMB)
	D	d	D1	L1	L	a									
SB-16-C16-110	15	16	3	30	110	45°	1	Ø3~Ø15	45°	SPMW0903	M4x8	T15	●	333820	200
SD-03-C12-110	12	12	4	30	110	45°	1	Ø4~Ø12	45°	SDMB26152	M3x7	T8	●	333822	200

SD-45°

内外倒角刀
Internal And External Chamfering

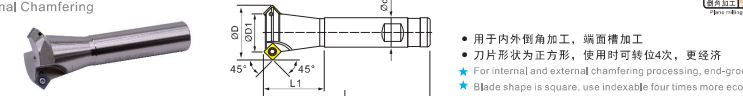

- 用于内外倒角加工, 端面槽加工
- 刀片形状为正方形, 使用时可换位4次, 更经济
- ★ For internal and external chamfering processing, end-groove.
- ★ Blade shape is square, use indexable four times more economical.

型号 Cat. No	尺寸 Size						刃数 No. of flutes	倒角范围 Chamfering range	角度 Angle	刀片 Insert	螺钉 Screw	扳手 Wrench	Stock	Order Number	Price (RMB)
	D	d	D1	L1	L	a									
SD-12-C16-110-1T	22	16	12	30	110	45°	1	Ø12~Ø22	45°	SDMB26152	M3x7	T8	●	333600	200
SD-25-C20-110-2T	25	20	15	30	110	45°	2	Ø15~Ø25	45°				●	333602	200
SD-20-C20-110-2T	30	20	22	30	110	45°	2	Ø22~Ø30	45°				●	333604	200
SD-30-C20-110-2T	40	20	30	30	110	45°	2	Ø30~Ø40	45°				●	333608	250
SD-40-C20-110-2T	50	20	40	30	110	45°	2	Ø40~Ø50	45°				●	333610	300

SSK45°

舍弃式倒角刀
SSK45° Discarding Chamfering



- 本铣刀可45° 切削, 亦可做倒角, V槽切削
- 适合一般铣床, CNC铣床, CNC车床, 钻床倒角
- ★ This cutter can be 45° cutting, chamfering can be done.
- ★ Suitable for general milling machine, integrated machining center.

型号 Cat. No	尺寸 Size						刃数 No. of flutes	倒角范围 Chamfering range	角度 Angle	刀片 Insert	螺钉 Screw	扳手 Wrench	Stock	Order Number	Price (RMB)
	D	d	D1	L1	L	a									
SSK-15-C12-110	15	12	5	30	110	45°	1	Ø5~Ø15	45°	AP..1135..	M2.5x6	T8	●	333710	200
SSK-16-C16-110	16	16	5	30	110	45°	1	Ø5~Ø16	45°				●	333712	200
SSK-20-C16-110	20	16	8	30	110	45°	1	Ø8~Ø20	45°	AP..1604..	M4x9	T15	●	333714	200
SSK-20-C20-130	20	20	8	30	130	45°	1	Ø8~Ø20	45°				●	333716	200
SSK-20-C20-200	20	20	8	30	200	45°	1	Ø8~Ø20	45°				●	333718	200
SSK-25-C25-120	25	25	10	30	120	45°	1	Ø10~Ø25	45°	●	333720	300			

■ BMC/MC 倒角刀
BMC/MC Chamfering

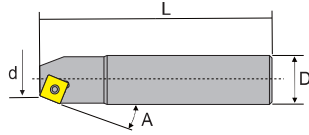

- 多种角度，适用孔背及反边倒角，减少二次装夹，省时高效！
- ★ A Variety Of Angles. Applicable Hole Back And The Edge Chamfer, Reduce Secondary Clamping, Time Efficient!

☞ 零配件 (Spare Parts): P01-P04

型号 Cat. No	尺寸 Size				刀片 Insert	螺钉 Screw	扳手 Wrench	Stock	Order Number	Price (RMB)
	直径 d	倒角角度 A	柄径 D	总长 L						
BMC09-3015D-C20-150	30	15	20	150	SDMT090308	M4x9	T10			
BMC09-3030D-C20-150	30	30	20	150						
BMC09-3045D-C20-150	30	45	20	150						
BMC09-3060D-C20-150	30	60	20	150						
MC09-1215D-C20-135	12	15	20	135						
MC09-1230D-C20-135	12	30	20	135						
MC09-1245D-C20-135	12	45	20	135						
MC09-1260D-C20-135	12	60	20	135						

■ 倒拉倒角刀
Inverted Chamfering

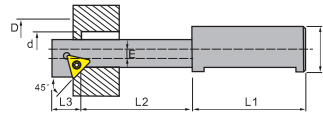

- 不用正反转，减少损坏概率
- 特殊设计本体刚性最佳
- ★ No need for reverse running of spindles that minimizes defect of tool.
- ★ Specially designed body gives maximum rigidity.

☞ 零配件 (Spare Parts): P01-P04

型号 Cat. No	尺寸 Size							刀片 Insert	螺钉 Screw	扳手 Wrench	Stock	Order Number	Price (RMB)
	D	d	C	L1	L2	L3	E						
BC-2014	20	14	16	48	40	13	3.2	TCMT110204 TCGT110204	M2.5x6.5	T8			
BC-2317	23	17	20	50	50	13	3.2						
BC-2721	27	21	25	56	70	13	3.2						
BC-3124	31	24	25	56	80	13	3.7						

■ 倒拉沉头刀
Inverted Countersunk Head

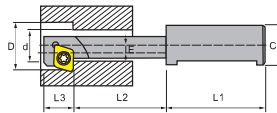

- 减少二次加工，增加微调机构
- 不用正反转，减少损坏概率
- 特殊设计本体刚性最佳

☞ 零配件 (Spare Parts): P01-P04

型号 Cat. No	尺寸 Size							刀片 Insert	螺钉 Screw	扳手 Wrench	Stock	Order Number	Price (RMB)
	D	d	C	L1	L2	L3	E						
M10-1810	18	10.5	16	48	35	13	4	CCMT060204 CCGT060204	M2.5x6.5	T8			
M12-2013	20	13	16	48	10	13	3.85						
M16-2617	26	17	20	50	50	13	4.85	CCMT09T308 CCGT09T308	M4x9	T15			
M20-3321	33	21	25	56	70	13	6.4						
M24-4025	40	25	25	56	80	13	7.9						

■ CA 双倒角沉头刀
CA Double Chamfer Countersunk Head Cutter

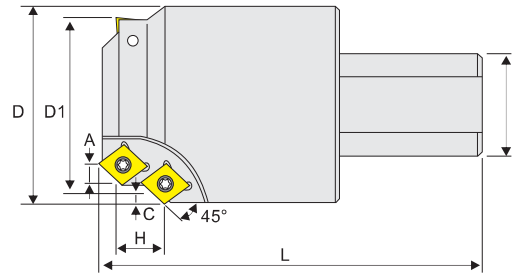

☞ 零配件 (Spare Parts): P01-P04

型号 Cat. No	刀具直径 D	底孔直径 D1	沉孔深度 H	倒角尺寸 A	倒角尺寸 C	柄部直径 d	总长 L	螺钉 Screw	扳手 Wrench	刀片 Insert	Stock	Order Number	Price (RMB)
CA1218-6.5	18	12	6.5	0.8	0.8	25	100	T8	M2.5X6	CCMT0602..			
CA1521-6.5	21	15	6.5	1.0	0.8	25	120						
CA1622-6.5	22	16	6.5	1.0	0.8	25	120						
CA2026-6.5	26	20	6.5	1.0	0.8	25	120						
CA2026-8.5	26	20	8.5	1.0	0.8	25	120						
CA2531-6.5	31	25	6.5	1.0	0.8	32	120	T15	M4.0X9	CCMT09T3..			
CA2531-8.5	31	25	8.5	1.0	0.8	32	120						
CA2531-10.5	31	25	10.5	1.0	0.8	32	120						
CA3036-8.5	36	30	8.5	1.0	0.8	32	120						
CA3036-10.5	36	30	10.5	1.0	0.8	32	120						
CA3541-8.5	41	35	8.5	1.0	0.8	32	120						
CA3541-10.5	41	35	10.5	1.0	0.8	32	120						
CA4046-10.5	46	40	10.5	1.0	0.8	32	120						
CA4248-10.5	48	42	10.5	1.0	0.8	32	120						
CA4552-10.5	52	45	10.5	1.0	0.8	32	120						
CA4855-10.5	55	48	10.5	1.0	0.8	32	120						
CA5057-12.5	57	50	12.5	1.0	0.8	32	120						
CA5562-10.5	62	55	10.5	1.0	0.8	32	120						
CA6067-15.5	67	60	15.5	1.0	0.8	40	130						
CA7077-12.5	77	70	12.5	1.0	0.8	40	130						
CA7077-15.5	77	70	15.5	1.0	0.8	40	130						
CA8088-15.5	88	80	15.5	1.0	0.8	40	130						
CA8088-20.5	88	80	20.5	1.0	0.8	40	130						
CA9098-20.5	98	90	20.5	1.0	0.8	40	130						

刀杆
刀盘

直角
台肩
立
铣刀

圆角
铣刀

球头
铣刀

钻头
刀杆

倒角
刀杆

玉米
铣刀

三面
刃
槽刀

快
进
给
系列

龙门
平面
铣刀

铣
牙
式
刀柄

可转位玉米型铣削刀具 (推荐切削参数)

Indexable corn milling cutter (Recommended cutting parameters)

槽铣加工
Groove milling

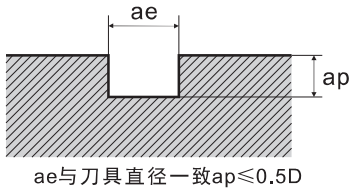

方肩台阶铣
Step milling

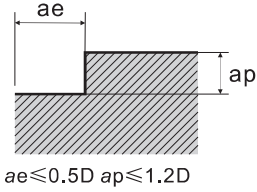

深方肩台阶铣
Deep step milling

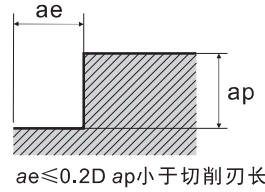

被加工材料 Processed Material	硬度 HB	刀片材质 Inserts Material	切削用量 Cutting amount			
			方肩台阶铣 Square shoulder milling			
			Vc (m/min)	f (mm/z)		
			精加工 Finish	中切削 Medium	重切削 Heavy	
低碳钢、软钢 Mild Steels	≤180	ZP151 ZP163	270(240-350)	0.1(0.08-0.2)	0.2(0.1-0.3)	0.25(0.2-0.35)
		ZP201	220(180-300)	0.1(0.08-0.2)	0.2(0.1-0.3)	0.25(0.2-0.35)
		ZP153	270(200-360)	0.1(0.08-0.2)	0.2(0.1-0.3)	0.25(0.2-0.35)
		ZP152	240(180-350)	0.1(0.08-0.2)	0.2(0.1-0.3)	0.25(0.2-0.35)
高碳钢、合金钢 Carbon Steel & Alloy Steels	180-280	ZP151 ZP163	240(210-320)	0.1(0.08-0.2)	0.2(0.1-0.3)	0.25(0.2-0.35)
		ZP201	200(160-280)	0.1(0.08-0.2)	0.2(0.1-0.3)	0.25(0.2-0.35)
		ZP153	240(180-360)	0.1(0.08-0.2)	0.2(0.1-0.3)	0.25(0.2-0.35)
		ZP152	220(150-330)	0.1(0.08-0.2)	0.2(0.1-0.3)	0.25(0.2-0.35)
合金工具钢 Die Steel	280-350	ZP151 ZP163	220(180-300)	0.1(0.08-0.2)	0.2(0.1-0.3)	0.25(0.2-0.35)
		ZP201	180(150-250)	0.1(0.08-0.2)	0.2(0.1-0.3)	0.25(0.2-0.35)
		ZP153	220(160-340)	0.1(0.08-0.2)	0.2(0.1-0.3)	0.25(0.2-0.35)
		ZP152	200(120-300)	0.1(0.08-0.2)	0.2(0.1-0.3)	0.25(0.2-0.35)
不锈钢 Stainless Steels	≤270	ZP153	170(120-240)	0.1(0.08-0.2)	0.2(0.1-0.3)	0.25(0.2-0.35)
		ZP152	160(150-270)	0.1(0.08-0.2)	0.2(0.1-0.3)	0.25(0.2-0.35)
		ZP151	150(110-270)	0.1(0.08-0.2)	0.2(0.1-0.3)	0.25(0.2-0.35)
		ZP150	140(100-250)	0.1(0.08-0.2)	0.2(0.1-0.3)	0.25(0.2-0.35)
铸铁 Cast Iron	180-250	ZK50S	200(120-240)	0.1(0.08-0.2)	0.2(0.1-0.3)	
		ZK50	180(120-300)	0.1(0.08-0.2)	0.2(0.1-0.3)	
-AL						
铝合金 Aluminum	---	ZK01	300-	0.2(0.08-0.4)		
		PCD	300-	0.2(0.08-0.4)		

APK 玉米立铣刀杆
APK Corn End Milling Cutter

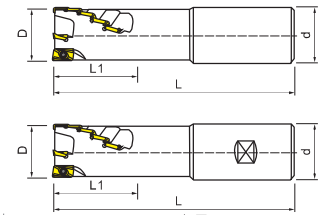

切削参数 (Cutting Parameters): D51
零配件 (Spare Parts): P01-P04

- 高效能型粗铣刀，能加工深孔。
- 尺寸可由刀杆随意变换深度，发挥最大效能。
- ★ High-performance-based rough milling, deep hole can be processed.
- ★ Arbor size can be arbitrarily change the depth of maximum efficiency.

C50.8 如图

型号 Cat. No	尺寸 Size				刀片数 No. of Flutes	刀片数 T	刀片 Insert	螺钉 Screw	扳手 Wrench	Stock	Order Number	Price (RMB)
	D	d	L1	L								
C20-20AP11-28-125-2T	20	20	28	125	2	6				●	334500	1750
C20-20AP11-35-110-2T	20	20	35	110	2	8	AP..1135..	M2.5X6	T8	●	334502	1040
C25-25AP11-38-130-2T	25	25	38	130	2	8				●	334504	1900
C25-25AP11-35-120-2T	25	25	35	120	2	8				●	334506	1280
C32-32AP11-48-150-3T	32	32	48	150	3	12				●	334508	2750
C32-32AP16-55-135-2T	32	32	55	135	2	8				●	334510	1440
C32-40AP16-70-150-3T	40	32	70	150	3	12	AP..1604..	M4.0X12	T15	●	334512	3000
C32-40AP16-55-135-2T	40	32	55	135	2	8				●	334514	1680
C32-50AP16-55-135-4T	50	32	55	135	4	16				●	334516	1880
C50.8-50AP16-80-205-3T	50	50.8	80	205	3	18	APKT1504..	M5	T20	●	334518	6440
C50.8-50AP16-125-250-3T	50	50.8	125	250	3	29	SPMT45272..			●	334520	6480

AP 整体式玉米型粗铣刀

AP Integral Type Maize Rough Milling Cutter

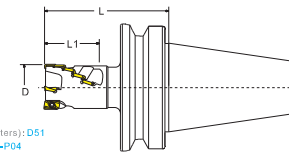

切削参数 (Cutting Parameters): D51
零配件 (Spare Parts): P01-P04



订购编码 Order	规格型号 Specification	Dimensions			刀片数 T	刃数 Edge	价格 Price
		D	L1	L			
334550	BT40-50AP16-70-125-4T	50	70	125	16	4	10000
334552	BT40-63AP16-110-160-4T	63	110	160	24	4	16800
334554	BT50-80AP16-165-250-4T	80	165	250	36	4	20000

配件(Accessory): 刀片: APMT1604.. 螺钉: M4X10 扳手: T15

APC 玉米型粗铣刀盘

Corn Type Rough Milling Cutter

- 高效能型粗铣刀，能加工深孔。
- 尺寸可由刀杆随意变换深度，发挥最大效能。
- ★ High-performance-based rough milling, deep hole can be processed.
- ★ Arbor size can be arbitrarily change the depth of maximum efficiency.

切削参数 (Cutting Parameters): D51
零配件 (Spare Parts): P01-P04

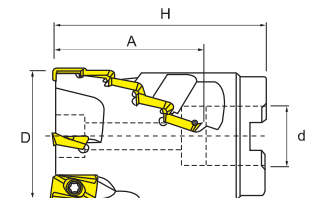

型号 Cat. No	尺寸 Size				刀片数 T	刀片 Insert	螺钉 Screw	扳手 Wrench	Stock	Order Number	Price (RMB)
	D	d	A	H							
D50AP16-22-42-65-3T	50	22	42	65	9				●	334530	2750
D50AP16-22-70-90-4T	50	22	70	90	16				●	334532	3040
D63AP16-27-42-65-4T	63	27	42	65	12				●	334534	3000
D63AP16-22-70-90-4T	63	22	70	90	16				●	334536	3280
D80AP16-32-70-100-5T	80	32	70	100	16	APKT1604	M4	T15	●	334538	3750
D80AP16-27-110-135-4T	80	27	110	135	24				●	334540	3720

侧铣槽铣
有孔
粗加工

		切削形态: ● 稳定切削 Stable Cutting ● 一般切削 General Cutting ✖ 不稳定切削 Unstable Cutting			
P	钢	Steel	●●●●●●●●	●●●●●●●●	●●●●●●●●
M	不锈钢	Stainless Steel	●●●●●●●●	●●●●●●●●	●●●●●●●●
K	铸铁	Iron	●●●●●●●●	●●●●●●●●	●●●●●●●●
N	铝/铜/钛/塑料/木材	Aluminum/Copper/Magnesium/Zinc/Plastic/Wood	●●●●●●●●	●●●●●●●●	●●●●●●●●
S	硬质合金/粉末冶金	Carbide/Powder Metallurgy	●●●●●●●●	●●●●●●●●	●●●●●●●●
H	钛/高温合金/碳纤维	Titanium/Superalloy/Carbon Fiber	●●●●●●●●	●●●●●●●●	●●●●●●●●

用途 Product Image	几何尺寸 Dimensioning	规格型号 Specification	尺寸 Dimension (mm)				配套刀柄 Matching Toolholder
			φE	A	B	T	
		APKT 150412-PM	1.2	16.33	12.7	4.76	刀柄: (Toolholder) D53-D54
		150412-KM	1.2	16.33	12.7	4.76	
		150412-KM	1.2	16.33	12.7	4.76	
		SPMT 120408-PM	0.8	12.7	12.7	4.76	刀柄: (Toolholder) D53-D54
		120408-KM	0.8	12.7	12.7	4.76	

SPM 玉米立铣刀杆
SPM Corn End Mill

切削参数 (Cutting Parameters): D51
零配件 (Spare Parts): P01-P04

- 高效能型粗铣刀, 能加工深孔。
- 尺寸可由刀杆随意变换深度, 发挥最大效能。
- ★ High-performance-based rough milling, deep hole can be processed.
- ★ Arbor size can be arbitrarily change the depth of maximum efficiency.

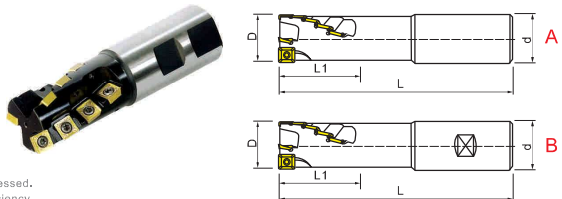

型号 Cat. No	尺寸 Size				图示 Figure	刃数 No. of flutes	刀片 Insert				螺钉 Screw	扳手 Wrench	Stock	Order Number	Price (RMB)
	D	d	L1	L			T	□	T	□					
SPM-32-120-40-C32	32	32	40	120	A	3							●	334600	1200
SPM-32-150-40-C32	32	32	40	150	A	3			SCMT09T304	M4	T15		●	334602	1300
SPM-38-120-40-C32	38	32	40	120	A	3							●	334604	1400
SPM-38-150-40-C32	38	32	40	150	A	3			SCMT09T308				●	334606	1500
SPM-40-150-50L-C32	40	32	50	150	A	4	2	P27215-3	SDMT090308	M4	T15		●	334608	1600
SPM-40-170-56L-C42	40	42	56	170	B	2	1	LPMT1504	SPMT1204	M5	T20		●	334610	1800
SPM-50-200-77L-C42	50	42	77	200	B	4	2	LPMT1504	SPMT1204	M5	T20		●	334612	2000
SPM-50-250-158-C42	50	42	158	250	B	4	2	LPMT1504	SPMT1204	M5	T20		●	334614	2200

SPC 玉米型粗铣刀盘
Corn Type Rough Milling Cutter

切削参数 (Cutting Parameters): D51
零配件 (Spare Parts): P01-P04

- 高效能型粗铣刀, 能加工深孔。
- 尺寸可由刀杆随意变换深度, 发挥最大效能。
- ★ High-performance-based rough milling, deep hole can be processed.
- ★ Arbor size can be arbitrarily change the depth of maximum efficiency.

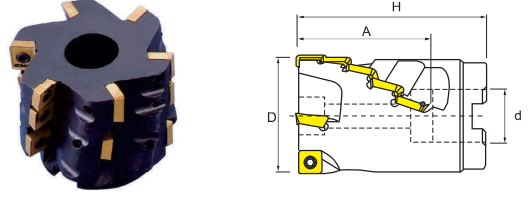

型号 Cat. No	尺寸 Size				刃数 T	刀片 Insert				螺钉 Screw	扳手 Wrench	Stock	Order Number	Price (RMB)	
	D	d	A	H		□	T	□	T						
SPC-80-31.75-80L	80	31.75	67	80	6								●	334400	3200
SPC-80-32-80L	80	32	67	80	6	LPMT1504	3	SPMT1204	18	M5	T20		●	334402	3200
SPC-100-40-100L	100	40	77	100	8	LPMT1504	4	SPMT1204	24	M5	T20		●	334404	4500

SPC 整体式玉米型粗铣刀

SPC Integral Type Maize Rough Milling Cutter

切削参数 (Cutting Parameters): D51
零配件 (Spare Parts): P01-P04



- 整体式结构, 切削刚性更好!
- 多种切深长度, 灵活选择。
- ★ The overall structure, cutting better rigidity!
- ★ A variety of cutting length, flexible choice.

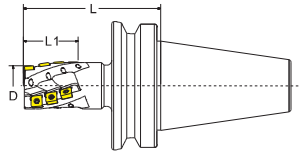

配件(Accessory):
刀片: LPMT1504., SPMT1204.,
螺钉: M5X12
扳手: T20

订购编码 Order	规格型号 Specification	Dimensions			刀片数 T	刃数 Edge	价格 Price
		D	L1	L			
334214	BT40-SPC40-60	40	60	107	4	8000	
334216	BT40-SPC50-60	50	60	117	4	8000	
334218	BT50-SPC50-60	50	60	138	4	9000	
334220	BT50-SPC63-80	63	80	153	4	9000	
334222	BT50-SPC80-120	80	120	188	4	10000	
334224	BT50-SPC80-150	80	150	203	4	11000	

HMP01 整体式玉米型粗铣刀

HMP01 Integral Type Maize Rough Milling Cutter

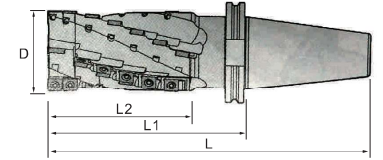
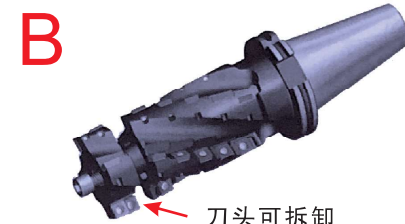
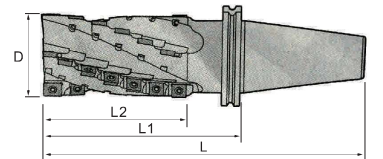
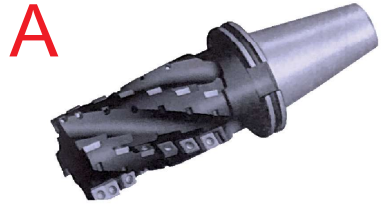

刀头可拆卸
Detachable head

切削参数 (Cutting Parameters): D51
零配件 (Spare Parts): P01-P04

型号 Cat. No	尺寸 Size				图示 Figure	槽数 Edges	刀片 Insert				螺钉 Screw	扳手 Wrench	Order Number	Price (RMB)	
	D	L2	L1	L			T	□	T	□					
HMP01- 050-84-BT50-SP12	50	84	145	246	A	4	2							334620	9000
063-74-BT50-SP12	63	74	135	236	A	4	2							334622	9000
063-104-BT50-SP12	63	104	165	266	A	4	2							334624	9000
063-134-BT50-SP12	63	134	195	296	A	4	2	AKPT1504	SPMT1204	M5x13	T20			334628	10000
080-104-BT50-SP12	80	104	165	266	A	4	2							334628	10000
080-144-BT50-SP12	80	144	205	306	A	4	2							334630	12000
HMP01- 050-84EC-BT50-SP12	50	84	145	246	B	4	2							334632	10000
063-74EC-BT50-SP12	63	74	135	236	B	4	2							334634	10000
063-104EC-BT50-SP12	63	104	165	266	B	4	2							334635	12000
063-134EC-BT50-SP12	63	134	195	296	B	4	2	AKPT1504	SPMT1204	M5x13	T20			334636	13000
080-104EC-BT50-SP12	80	104	165	266	B	4	2							334637	12000
080-144EC-BT50-SP12	80	144	205	306	B	4	2							334639	13000

TT 正三角
有孔
切槽加工

用途 Application	产品图片 Product Image	几何尺寸 Dimensioning	规格型号 Specification	尺寸 Dimension (mm)						配套刀柄 Matching Toolholder	材料 Material
				rE	A	B	T	a			
切槽刀片 Slotting Insert			TGF32L 150	0.1	16	2.0	3.18	1.5	刀柄: (Toolholder) D55-D56	P M K N S H	
			200	0.15	2.8		2.0				
			250	0.15	2.8		2.5				
			300	0.15	2.8		3.0				
切槽刀片 Slotting Insert			TGF32L 150-R0.75	0.75	16	2.0	3.18	R0.75	刀柄: (Toolholder) D55-D56	P M K N S H	
			200-R1.0	1.0	2.8		R1.25				
			250-R1.25	1.25	2.8		R1.5				
			300-R1.5	1.5	2.8						
切槽刀片 Slotting Insert			TT43L 200	0.2	22	4.8	5.0	2.0	刀柄: (Toolholder) D55-D56	P M K N S H	
			250	0.2			2.5				
			300	0.2			3.0				
			400	0.2			4.0				
切槽刀片 Slotting Insert			TT43L 200-R1.0	1.0	22	4.8	5.0	R1.0	刀柄: (Toolholder) D55-D56	P M K N S H	
			250-R1.25	1.25			R1.25				
			300-R1.5	1.5			R1.5				
			400-R2.0	2.0			R2.0				

■ SMT T型槽铣刀
T-Slot Side Mill

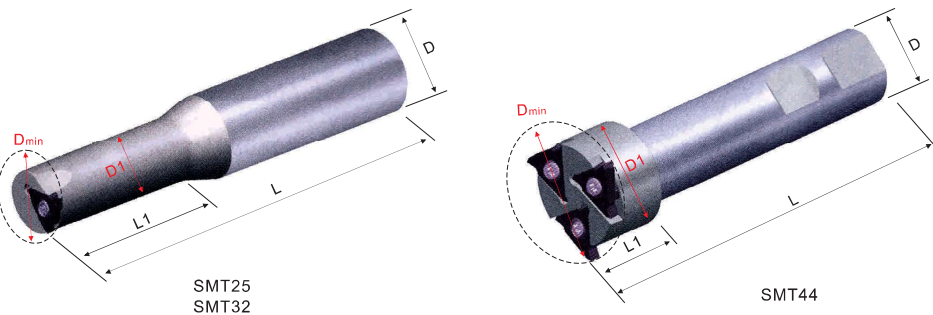

零配件 (Spare Parts): P01-P04

型号 Cat. No	尺寸 Size						刃数 No. of flutes	刀片 Insert	螺钉 Screw	扳手 Wrench	Stock	Order Number	Price (RMB)
	Dmin	D	D1	L	L1								
SMT 25-25KT32-1	25	25	17	125	56		1	TGF32L	M3.5 × 10	T15	●	335530	500
32-32KT32-1	32	32	24	125	77		1	TGF32L	M3.5 × 10	T15	●	335532	600
39-25KT32-3	39	25	30	125	23		3	TT43L	M5 × 13	T20	●	335534	800
44-25KT43-3	44	25	36	125	23		3	TT43L	M5 × 13	T20	●	335536	1000

■ SMT T型槽铣刀盘
T-Slot Side Mill

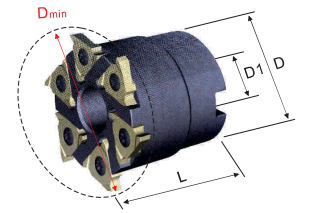

零配件 (Spare Parts): P01-P04

型号 Cat. No	尺寸 Size					刃数 No. of flutes	刀片 Insert	螺钉 Screw	扳手 Wrench	Stock	Order Number	Price (RMB)
	Dmin	D	D1	L								
SMT 63-22T43-6	63	50	22	50		6	TT43L	M5 × 13	T20	●	335538	900
80-27T43-8	80	50	27	50		8	TT43L	M5 × 13	T20	●	335539	1200

■ ATS T型槽铣刀
T-Slot Side Mill

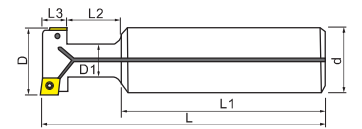

零配件 (Spare Parts): P01-P04

型号 Cat. No	尺寸 Size							刃数 No. of flutes	刀片 Insert	螺钉 Screw	扳手 Wrench	Stock	Order Number	Price (RMB)
	D	d	D1	L	L1	L2	L3							
ATS-24-11	24	25	12.5	112	80	21	11	2	CCMT060204	M2.5 × 6	T8	●	335500	300
ATS-31-14	31	32	16	120	77	30	14	4	CCMT080304	M3 × 7	T10	●	335502	320
ATS-39-18	39	32	20	130	80	32	18	4	CCMT09T308	M4 × 10	T15	●	335504	350
ATS-49-22	49	32	26	140	80	39	22	4	CCMT120408	M5 × 11	T20	●	335506	400

■ 890 一体式高速强力T形刀
890 Integrated high power T cutter

零配件 (Spare Parts): P01-P04

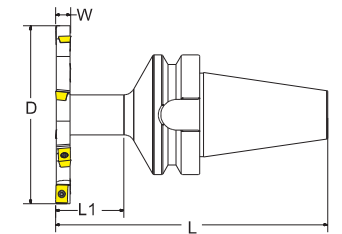

- 高刚性一体式结构，使型腔加工更加轻松！
- ★ High rigid integral structure, so that the cavity processing more easily!

型号 Cat. No	刃数 Blade number	直径 Diameter	切削宽度 Cutting width	d	L	刀片 Insert	Stock	Order Number	Price (RMB)
890-220172R98.5-BT40	8	98.5	8	21	36	N331.1A-054508	●	335100	2600
890-220172R96-BT40	8	96	8	21	36		●	335102	2900
890-220172R115-BT40	8	115	8	21	36		●	335104	3400

刀杆
刀盘

直角
台肩
立
铣刀

圆角
铣刀

球头
铣刀

钻铣
刀杆

倒角
刀杆

玉米
铣刀

三
面
刃
槽
刀

快
进
给
系
列

龙
门
平
面
铣
刀

锁
牙
式
刀
柄

刀杆
刀盘

直角
台肩
立
铣刀

圆角
铣刀

球头
铣刀

钻铣
刀杆

倒角
刀杆

玉米
铣刀

三
面
刃
槽
刀

快
进
给
系
列

龙
门
平
面
铣
刀

锁
牙
式
刀
柄

MPHT 槽加工
有孔
铣削加工

用途 Application	产品图片 Product Image	几何尺寸 Dimensioning	规格型号 Specification	尺寸 Dimension (mm)				配磨刀柄 Matching Toolholder
				r _e	A	B	T	
铣削刀片 Milling Cutter			MPHT 060304-DM 080305-DM 120408-DM	0.4 0.5 0.8	6.35 8.3 12.7	6.35 8.3 12.7	3.18 3.18 4.76	刀柄: (Toolholder) D57-D58

■ DMP 三面刃铣刀(卡口型)
DMP three-sided edge milling cutter (bayonet type)

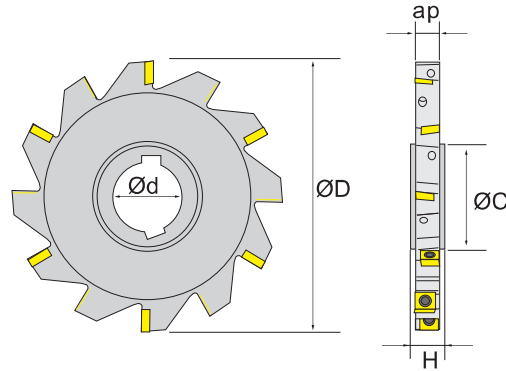

■ 零配件 (Spare Parts): P01-P04

型号 Cat. No	尺寸 Size					齿数 Z	刀片 Insert	螺钉 Screw	扳手 Wrench	Stock	Order Number	Price (RMB)
	ØD	ØC	Ød	ap	H							
DMP06-08008-K27	80	41	27	8	12	10	MP=T060304	M2.5X6.5	T8	●	335200	1400
DMP06-10008-K32	100	47	32	8	12	14				●	335202	1500
DMP06-10010-K32	100	47	32	10	14	14				●	335204	1500
DMP06-12510-K40	125	55	40	10	14	16	MP=T080305	M3X7	T10	●	335206	1700
DMP08-12512-K40	125	55	40	12	16	12				●	335208	1700
DMP08-16012-K40	160	62	40	12	16	14				●	335210	2300
DMP12-16012-K40	160	62	40	16	20	12	MP=T120408	M5X13	T20	●	335212	2300
DMP12-16018-K40	160	62	40	18	24	12				●	335214	2300
DMP12-16020-K40	160	62	40	20	26	12				●	335216	2300
DMP12-20016-K50	200	72	50	16	20	14				●	335218	2800
DMP12-20018-K50	200	72	50	18	24	14				●	335220	2800
DMP12-20020-K50	200	72	50	20	26	14				●	335222	2800

■ DMP T型槽铣刀
T-Slot Side Mill

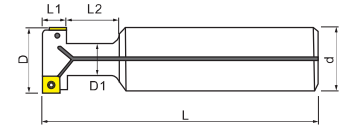

■ 零配件 (Spare Parts): P01-P04

型号 Cat. No	尺寸 Size						刀数 No. of flutes	刀片 Insert	螺钉 Screw	扳手 Wrench	Stock	Order Number	Price (RMB)
	D	d	D1	L	L1	L2							
DMP06-21-9	21	25	10	100	9	32	1	MPHT0603..	M2.5×6	T8	●	335510	400
DMP06-25-11	25	25	12	100	11	35	1	MPHT0603..	M2.5×6	T8	●	335512	500
DMP08-32-14	32	32	15	110	14	45	2	MPHT0803..	M3×7	T10	●	335514	600
DMP12-40-18	40	32	19	125	18	55	2	MPHT1204..	M5×11	T20	●	335516	700
DMP12-50-22	50	40	25	140	22	65	2	MPHT1204..	M5×11	T20	●	335518	800

■ DMP 三面刃铣刀(刀盘型)
DMP Three-sided Edge Milling Cutter (cutter Type)

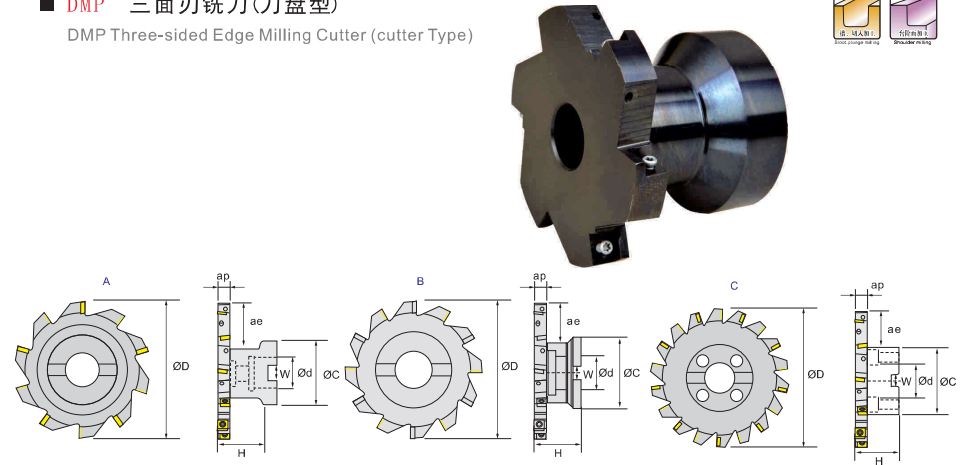

■ 零配件 (Spare Parts): P01-P04

型号 Cat. No	尺寸 Size						齿数 Z	刀片 Insert	螺钉 Screw	扳手 Wrench	Stock	Order Number	Price (RMB)
	ØD	ØC	Ød	ap	W	H							
DMP06-08008-B22	80	45	22	8	10.4	40	10	MP=T060304	M2.5X6.5	T8	●	335300	1500
DMP06-10008-B27	100	55	27	8	12.4	40	14				●	335302	1600
DMP06-10010-B27	100	55	27	10	12.4	40	14				●	335304	1600
DMP06-12510-B32	125	65	32	10	14.4	50	16	MP=T080305	M3X7	T10	●	335306	1800
DMP08-12512-B32	125	65	32	12	14.4	50	12				●	335308	1800
DMP08-16012-B40	160	89	40	12	16.4	50	14				●	335310	2500
DMP08-20012-B40	200	89	40	12	16.4	50	18	MP=T120408	M5X13	T20	●	335312	3000
DMP12-12512-B32	125	65	32	16	14.4	50	10				●	335314	1800
DMP12-16016-B40	160	89	40	16	16.4	50	12				●	335316	2500
DMP12-16018-B40	160	89	40	18	16.4	50	12				●	335318	2500
DMP12-16020-B40	160	89	40	20	16.4	50	12				●	335320	2500
DMP12-20016-B40	200	89	40	16	16.4	50	14				●	335322	3000
DMP12-20018-B40	200	89	40	18	16.4	50	14				●	335324	3000
DMP12-20020-B40	200	89	40	20	16.4	50	14				●	335326	3000

SPMG 钻孔/槽加工
有孔
铣削加工

切削形态			精密切削	一般切削	不稳定切削
Cutting Environment			Stable Cutting	General Cutting	Unstable Cutting
P	钢	Steel	●	○	✖
M	不锈钢	Stainless Steel	●	○	✖
K	铸铁	Iron	●	○	✖
N	铝/铜/钛/塑料/木材	Aluminum/Copper/Magnesium/Zinc/Plastic/Wood	●	○	✖
S	硬质合金/粉末冶金	Carbide/Powder Metallurgy	●	○	✖
H	钛/高温合金/碳纤维	Titanium/Superalloy/Carbon Fiber	●	○	✖

用途	产品图片	几何尺寸	规格型号	尺寸 Dimension (mm)				配套刀柄
				rE	A	B	T	
机夹式 三面刃铣刀			SPMG 050204-TT	0.4	5.0	5.0	2.38	刀柄: (Toolholder) D59-D60
			060204-TT	0.4	6.0	6.0	2.38	
			07308-TT	0.8	7.94	7.94	3.97	
			090408-TT	0.8	9.8	9.8	4.30	
			110408-TT	0.8	11.5	11.5	4.8	
140512-TT	1.2	14.3	14.3	5.0				

■ SMP 三面刃铣刀(刀盘型)

SMP Three-sided Edge Milling Cutter (Cutter Type)

零件 (Spare Parts): P01-P04

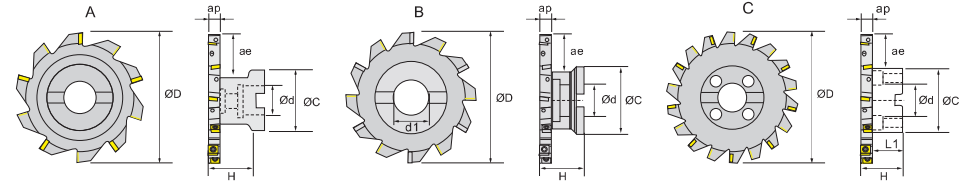

■ SMP 三面刃铣刀(卡口型)

SMP three-sided edge milling cutter (bayonet type)

零件 (Spare Parts): P01-P04

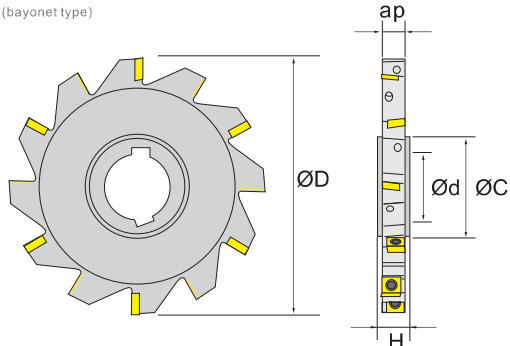

型号 Cat. No	尺寸 Size						刀片 Insert	螺钉 Screw	扳手 Wrench	Stock	Order Number	Price (RMB)
	ØD	ap	Ød	H	ØC	T						
SMP-80-06-8T-K22	6						SPMG050204	TS2003	T6	●	335900	1400
SMP-80-08-8T-K22	8						SPMG060204	TS2202	T6	●	335802	1400
SMP-80-10-8T-K22	10						SPMG07308	TS2511	T8	●	335604	1400
SMP-80-12-8T-K22	12						SPMG07308	TS2511	T8	●	335606	1400
SMP-100-06-10T-K27	6						SPMG050204	TS2003	T8	●	335608	1500
SMP-100-08-10T-K27	8						SPMG060204	TS2202	T8	●	335610	1500
SMP-100-10-10T-K27	10						SPMG07308	TS2511	T8	●	335612	1500
SMP-100-12-10T-K27	12						SPMG07308	TS2511	T8	●	335614	1500
SMP-100-14-10T-K27	14						SPMG090408	TS3504	T15	●	335616	1500
SMP-100-16-10T-K27	16						SPMG090408	TS3504	T15	●	335618	1500
SMP-125-06-12T-K32	6						SPMG050204	TS2003	T6	●	335620	1650
SMP-125-08-12T-K32	8						SPMG060204	TS2202	T6	●	335622	1650
SMP-125-10-12T-K32	10						SPMG07308	TS2511	T8	●	335624	1650
SMP-125-12-12T-K32	12						SPMG07308	TS2511	T8	●	335626	1650
SMP-125-14-12T-K32	14						SPMG090408	TS3504	T15	●	335628	1650
SMP-125-16-12T-K32	16						SPMG090408	TS3504	T15	●	335630	1650
SMP-125-18-10T-K32	18						SPMG110408	TS4006	T15	●	335632	1650
SMP-125-20-10T-K32	20						SPMG110408	TS4006	T15	●	335634	1650
SMP-125-25-10T-K32	25						SPMG140512	TS5009	T20	●	335636	1650
SMP-160-12-16T-K40	12						SPMG07308	TS2511	T8	●	335638	2300
SMP-160-16-16T-K40	16						SPMG090408	TS3504	T15	●	335640	2300
SMP-160-18-12T-K40	18						SPMG110408	TS4006	T15	●	335642	2300
SMP-160-20-12T-K40	20						SPMG110408	TS4006	T15	●	335644	2300
SMP-160-25-12T-K40	25						SPMG140512	TS5009	T20	●	335646	2300
SMP-200-16-18T-K40	16						SPMG090408	TS3504	T15	●	335648	2800
SMP-200-18-14T-K40	18						SPMG110408	TS4006	T15	●	335650	2800
SMP-200-20-14T-K40	20						SPMG110408	TS4006	T15	●	335652	2800
SMP-200-25-14T-K40	25						SPMG140512	TS5009	T20	●	335654	2800

刀杆刀盘

直角台肩立铣刀

圆角铣刀

球头铣刀

钻铣刀杆

倒角刀杆

玉米铣刀

三面刃槽刀

快进给系列

龙门平面铣刀

铣刀式刀柄

XSEQ 槽加工
有孔
铣削加工

用途 Application	产品图片 Product Image	几何尺寸 Dimensioning	规格型号 Specification	尺寸 Dimension (mm)				配套刀柄 Matching Toolholder
				r _c	A	B	T	
铣削刀片 Milling Cutter			XSEQ 1202	12.7	12.7	2.3	刀柄: (Toolholder) D61-D62	
			1203	12.7	12.7	3.0		
			12T3	12.7	12.7	3.5		
			1204	12.7	12.7	4.0		
			12T4	12.7	12.7	4.5		

■ SMP01 三面刃铣刀(卡口型)

SMP01 three-sided edge milling cutter (bayonet type)

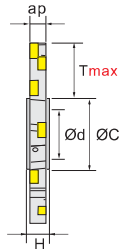
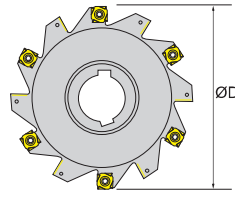

■ 零配件 (Spare Parts): P01-P04

型号 Cat. No	尺寸 Size						刀片 Insert	螺钉 Screw	扳手 Wrench	Stock	Order Number	Price (RMB)
	ØD	ap	Ød	H	ØC	Tmax						
SMP01- 100X4-K27-10		4					XSEQ1202	M4x3.2X	T15	●	335800	1500
100X5-K27-10		5					XSEQ1203	M4x4.2X		●	335802	1500
100X6-K27-10	100	6	27	12	45	25	XSEQ12T3	M4x5.1X		●	335804	1500
100X7-K27-10		7					XSEQ1204	M4x6.1X		●	335806	1500
100X8-K27-10		8					XSEQ12T4	M4x7.1X		●	335808	1500
SMP01- 125X4-K40-16		4					XSEQ1202	M4x3.2X	T15	●	335810	1800
125X5-K40-16		5					XSEQ1203	M4x4.2X		●	335812	1800
125X6-K40-16	125	6	40	12	56	32	XSEQ12T3	M4x5.1X		●	335814	1800
125X7-K40-16		7					XSEQ1204	M4x6.1X		●	335816	1800
125X8-K40-16		8					XSEQ12T4	M4x7.1X		●	335818	1800
SMP01- 160X4-K40-16		4					XSEQ1202	M4x3.2X	T15	●	335820	2000
160X5-K40-16		5					XSEQ1203	M4x4.2X		●	335822	2000
160X6-K40-16	160	6	40	12	67	45	XSEQ12T3	M4x5.1X		●	335824	2000
160X7-K40-16		7					XSEQ1204	M4x6.1X		●	335826	2000
160X8-K40-16		8					XSEQ12T4	M4x7.1X		●	335828	2000
SMP01- 200X6-K50-18		6					XSEQ12T3	M4x5.1X	T15	●	335830	3000
200X7-K50-18	200	7	50	12	71	62	XSEQ1204	M4x6.1X		●	335832	3000
200X8-K50-18		8					XSEQ12T4	M4x7.1X		●	335834	3000
SMP01- 250X6-K50-24		6					XSEQ12T3	M4x5.1X	T15	●	335836	4000
250X7-K50-24	250	7	50	12	71	87	XSEQ1204	M4x6.1X		●	335838	4000
250X8-K50-24		8					XSEQ12T4	M4x7.1X		●	335840	4000

■ SMP01 三面刃铣刀(刀盘型)

SMP01 Three-sided Edge Milling Cutter (Cutter Type)

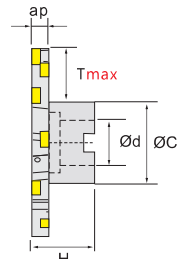
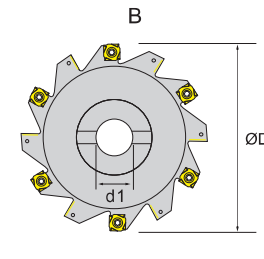
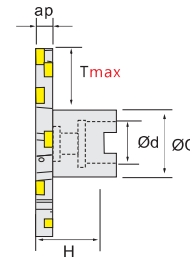
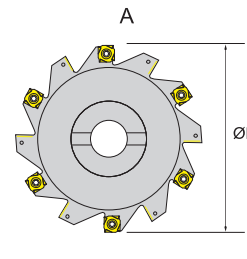

■ 零配件 (Spare Parts): P01-P04

型号 Cat. No	尺寸 Size						刀片 Insert	螺钉 Screw	扳手 Wrench	Stock	Order Number	Price (RMB)
	ØD	ap	Ød	H	ØC	Tmax						
SMP01- 063X4-A22-08		4					XSEQ1202	M4x3.2X	T15	●	335850	1500
063X5-A22-08		5					XSEQ1203	M4x4.2X		●	335852	1500
063X6-A22-08	63	6	22	40	32	14	XSEQ12T3	M4x5.1X		●	335854	1500
063X7-A22-08		7					XSEQ1204	M4x6.1X		●	335856	1500
063X8-A22-08		8					XSEQ12T4	M4x7.1X		●	335858	1500
SMP01- 080X4-A22-08		4					XSEQ1202	M4x3.2X	T15	●	335860	1800
080X5-A22-08		5					XSEQ1203	M4x4.2X		●	335862	1800
080X6-A22-08	80	6	22	50	40	18	XSEQ12T3	M4x5.1X		●	335864	1800
080X7-A22-08		7					XSEQ1204	M4x6.1X		●	335866	1800
080X8-A22-08		8					XSEQ12T4	M4x7.1X		●	335868	1800
SMP01- 100X4-A27-10		4					XSEQ1202	M4x3.2X	T15	●	335870	2000
100X5-A27-10		5					XSEQ1203	M4x4.2X		●	335872	2000
100X6-A27-10	100	6	27	50	48	23	XSEQ12T3	M4x5.1X		●	335874	2000
100X7-A27-10		7					XSEQ1204	M4x6.1X		●	335876	2000
100X8-A27-10		8					XSEQ12T4	M4x7.1X		●	335878	2000
SMP01- 125X6-B32-12		6					XSEQ12T3	M4x5.1X	T15	●	335880	3000
125X7-B32-12	125	7	32	50	70	30	XSEQ1204	M4x6.1X		●	335882	3000
125X8-B32-12		8					XSEQ12T4	M4x7.1X		●	335884	3000
SMP01- 160X6-B40-16		6					XSEQ12T3	M4x5.1X	T15	●	335886	4000
160X7-B40-16	160	7	40	50	70	41	XSEQ1204	M4x6.1X		●	335888	4000
160X8-B40-16		8					XSEQ12T4	M4x7.1X		●	335890	4000

刀杆刀盘
直角台肩立铣刀
圆角铣刀
球头铣刀
钻头刀杆
倒角刀杆
玉米铣刀
三面刃槽刀
快进给系列
龙门平面铣刀
锁牙式刀柄

AJX 快进给立铣刀
Fast Feed End Mill

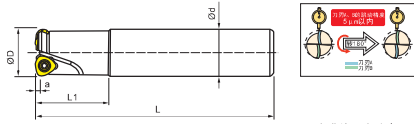

•高进给，高效率
★ The most suitable for large-feed cutting.

切削参数 (Cutting Parameters): R19
零配件 (Spare Parts): P01~P04

Table with columns: 型号 Cat. No, 尺寸 Size (D, d, L, L1, a), 刃数 No. of flutes, 刀片 Insert, 压板 Clamp, 螺钉 Screw, 扳手 Wrench, Stock, Order Number, Price (RMB).

刀杆 刀盘

直角 台肩 立 铣刀

圆角 铣刀

球头 铣刀

钻铣 刀杆

倒角 刀杆

玉米 铣刀

三面 刀槽刀

快 进给 系列

龙门 平面 铣刀

锁 牙式 刀柄

JDMW 平面高进给
单面有孔
铣削刀片

Table with columns: 用途, 产品图片, 几何尺寸, 规格型号, 尺寸 Dimension (mm), 配套刀柄, 材料, 应用.

AJX型 快进给面铣刀盘
Fast Feed Face Milling Cutter

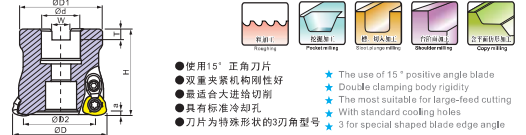

切削参数 (Cutting Parameters): R19
零配件 (Spare Parts): P01~P04

Table with columns: 型号 Cat. No, 尺寸 Size (D, D1, D2, d, H, W, T, a), 刀片 Insert, 压板 Clamp, 螺钉 Screw, 扳手 Wrench, Stock, Order Number, Price (RMB).

AJX高进给铣刀头
AJX High Feed Milling Head

■ 低转速 高进给
切削效率是普通圆鼻面铣刀盘的3倍
锥形设计, 刚性高

■ Low-speed, high feed
Cutting efficiency of an ordinary cutter round nose and face plate 3 times
Cone-design, steel high

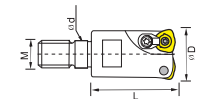

切削参数 (Cutting Parameters): R19
零配件 (Spare Parts): P01~P04

Table with columns: 型号 Cat. No, 尺寸 Size (D, L, d, M), Teeth, 刀片 Insert, 压板 Clamp, 螺钉 Screw, 扳手 Wrench, Stock, Order Number, Price (RMB).

刀杆 刀盘

直角 台肩 立 铣刀

圆角 铣刀

球头 铣刀

钻铣 刀杆

倒角 刀杆

玉米 铣刀

三面 刀槽刀

快 进给 系列

龙门 平面 铣刀

锁 牙式 刀柄

KM 机夹式45°平面立铣刀盘

45° Planar End Milling Cutter Head with Machine Clamp

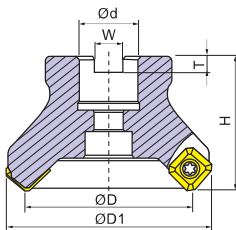

切削参数 (Cutting Parameters): R15-R16

零配件 (Spare Parts): P01-P04

- 适配钢件、铸件、铝件多种材质刀片, 通切范围广
- 容量空间大, 排屑好
- 可适用平面铣削的精加工
- 大前角, 切削负荷小
- ★ Fit steel, castings, aluminum pieces of various materials blade, the relevance of a wide range of
- ★ Capacity chip a large space, good chip disposal
- ★ Planar milling finishing applications
- ★ Large rake angle, cutting a small load

规格型号 Specification	尺寸 Dimensions (mm)						刃数 Edges	刀片 Insert	螺钉 Screw	扳手 Wrench	库存 Stock	编码 Code	Price (RMB)
	D	D1	d	H	W	T							
KM12R50-22-4T	50	64	22	50	10,4	6,3	4	SE..1204..	M5,0×11	T20	●	331500	240
KM12R63-22-4T	63	77	22	50	10,4	6,3	4					331502	280
KM12R80-27-5T	80	94	27	50	12,4	7	5					331504	400
KM12R100-32-5T	100	114	32	50	14,4	8	5					331506	600
KM12R125-40-6T	125	139	40	63	16,4	9	6					331508	750
KM12R160-40-6T	160	174	40	63	16,4	9	6					331510	1150
KM12R200-60-8T	200	210	60	63	25,7	14	8					331512	1600
KM12R250-60-10T	250	260	60	63	25,7	14	10					331514	2100
KM12R300-60-12T	300	310	60	65	25,7	14	12					331516	-
KM12R50-25,4-4T	50	64	25,4	50	10	6	4					331518	-
KM12R63-25,4-4T	63	77	25,4	50	10	6	4					331520	280
KM12R80-25,4-5T	80	94	25,4	50	10	6	5					331522	400
KM12R100-31,75-5T	100	114	31,75	50	13	8	5	331524	600				

AL-KM 机夹式45°平面立铣刀盘-铝制高光

45° Planar End Milling Cutter Head with Machine Clamp
-Aluminum High Gloss

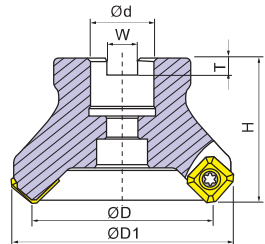

切削参数 (Cutting Parameters): R15-R18

零配件 (Spare Parts): P01-P04

- 特点: 铝材壳体, 重量轻, 45°高光效率高
- ★ Features: Aluminum Shell, Light Weight, 45° High Polishing Efficiency

规格型号 Specification	尺寸 Dimensions (mm)						刃数 Edges	刀片 Insert	螺钉 Screw	扳手 Wrench	库存 Stock	编码 Code	Price (RMB)
	D	d	H	W	T								
AL-KM12-50-22-4T	50	22	50	10,4	6,3	4	SE..1204..	M5,0×11	T20	●	331550	260	
AL-KM12-63-22-4T	63	22	50	10,4	6,3	4					331552	320	
AL-KM12-80-22-6T	80	22	50	12,4	7	6					331554	440	
AL-KM12-80-27-5T	80	27	50	12,4	7	5					331556	440	
AL-KM12-80-27-6T	80	27	50	12,4	7	6					331558	440	
AL-KM12-100-22-6T	100	22	50	14,4	7	6					331560	750	
AL-KM12-100-27-6T	100	27	50	14,4	8	6					331562	750	
AL-KM12-100-32-5T	100	32	50	14,4	8	5					331564	750	
AL-KM12-100-32-6T	100	32	50	14,4	8	6					331566	750	
AL-KM12-125-22-6T	125	22	63	16,4	8	6					331568	1165	
AL-KM12-125-27-6T	125	27	63	16,4	9	6					331570	1165	
AL-KM12-125-32-6T	125	32	63	16,4	9	6					331572	1165	
AL-KM12-125-40-6T	125	40	63	16,4	9	6					331574	1165	
AL-KM12-160-27-8T	160	27	63	16,4	9	8					331576	1300	
AL-KM12-160-32-8T	160	32	63	16,4	9	8					331578	1300	
AL-KM12-160-40-6T	160	40	63	16,4	9	6					331580	1300	
AL-KM12-160-40-8T	160	40	63	16,4	9	8					331582	1300	
AL-KM12-200-40-10T	200	40	63	16,4	9	10					331584	2800	
AL-KM12-200-60-8T	200	60	63	16,4	9	8					331586	2800	
AL-KM12-250-60-10T	250	60	63	16,4	9	10					331588	3500	
AL-KM12-300-60-12T	300	60	63	16,4	9	12					331590	4300	

SEKT 正四方形
有孔
铣削刀片

刀片(Insert):
SEMT13T3AGSN-JM ZP152
Ap:0,3-0,8 (mm)
Fz:0,1-0,3 (mm/rev)
Vc:100-300 (m/min)

- 切削形态: 稳定切削 一般切削 不稳定切削
- Cutting Environment ● Stable Cutting ● General Cutting ● Unstable Cutting

用途 Application	产品图片 Product Image	几何尺寸 Dimensioning	规格型号 Specification	尺寸 Dimension (mm)						配套刀柄 Matching Toolholder	适用材质 Applicable Material
				r/c	A	B	T	Ød	a°		
平面铣削加工 Planar Milling			SECA 1204AFSN 1204AFTN	-	12,7	2,66	4,76	5,56	20°	刀柄: (Toolholder) D75	●●●●
平面铣削加工 Planar Milling			SEKT 1204AFTN	-	12,7	2,66	4,76	5,56	20°	刀柄: (Toolholder) D75	●●●●
平面铣削加工 Planar Milling			SEHT 1204AFSN	-	12,7	2,66	4,76	5,56	20°	刀柄: (Toolholder) D75	●●●●
平面铣削加工 Planar Milling			SEHT 1204-AK	-	12,7	2,66	4,76	5,56	20°	刀柄: (Toolholder) D75	●
平面铣削加工 Planar Milling			SEHT 1204	-	12,7	2,66	4,76	5,56	20°	刀柄: (Toolholder) D75	●
平面铣削加工 Planar Milling			SEHT 1204	-	12,7	2,66	4,76	5,56	20°	刀柄: (Toolholder) D75	●●



- 刀杆刀盘
- 直角台肩立铣刀
- 圆角铣刀
- 球头铣刀
- 钻铣刀杆
- 倒角刀杆
- 玉米铣刀
- 三面刃槽刀
- 快进给系列
- 龙门平面铣刀
- 锁牙式刀柄

- 刀杆刀盘
- 直角台肩立铣刀
- 圆角铣刀
- 球头铣刀
- 钻铣刀杆
- 倒角刀杆
- 玉米铣刀
- 三面刃槽刀
- 快进给系列
- 龙门平面铣刀
- 锁牙式刀柄

