

小零件加工专用刀具

Special tool for small parts processing

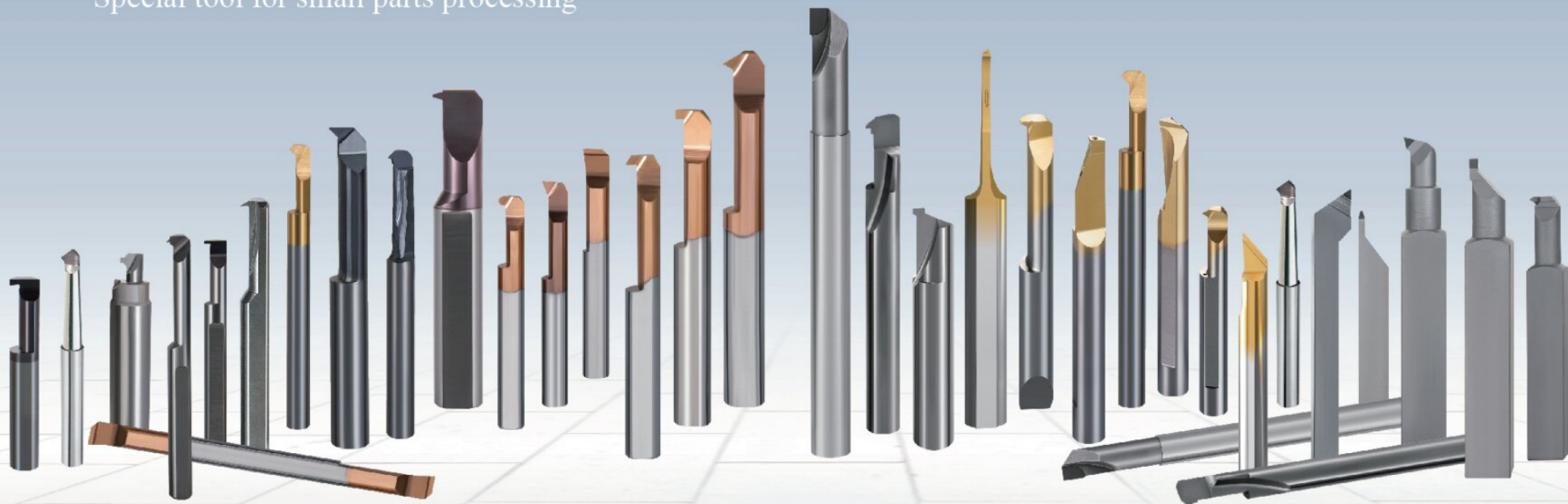

应用

- 内孔车削
- 成型加工
- 背镗
- 仿形加工
- 切槽
- 端面切槽
- 预切断
- 螺纹切削

ISO应用范围

P M N S H

优点和特点

- ▲ 针对小零件的高质量加工而优化
- ▲ 高精度和重复性
- ▲ 可靠且易用的夹紧系统
- ▲ 确保高重复性的精磨刀具
- ▲ 硬质合金圆柱直柄接杆可减小振动,实现更长刀具寿命
- ▲ 夹紧螺母确保易于更换

微型镗刀

Micro boring tool

用于小孔加工的整体硬质合金刀具

适合电子、医疗、小零件加工行业，所有刀具都可以带有内冷孔，冷却液直接喷射在切削刃口，排屑流畅，切削轻快，提高刀具寿命。

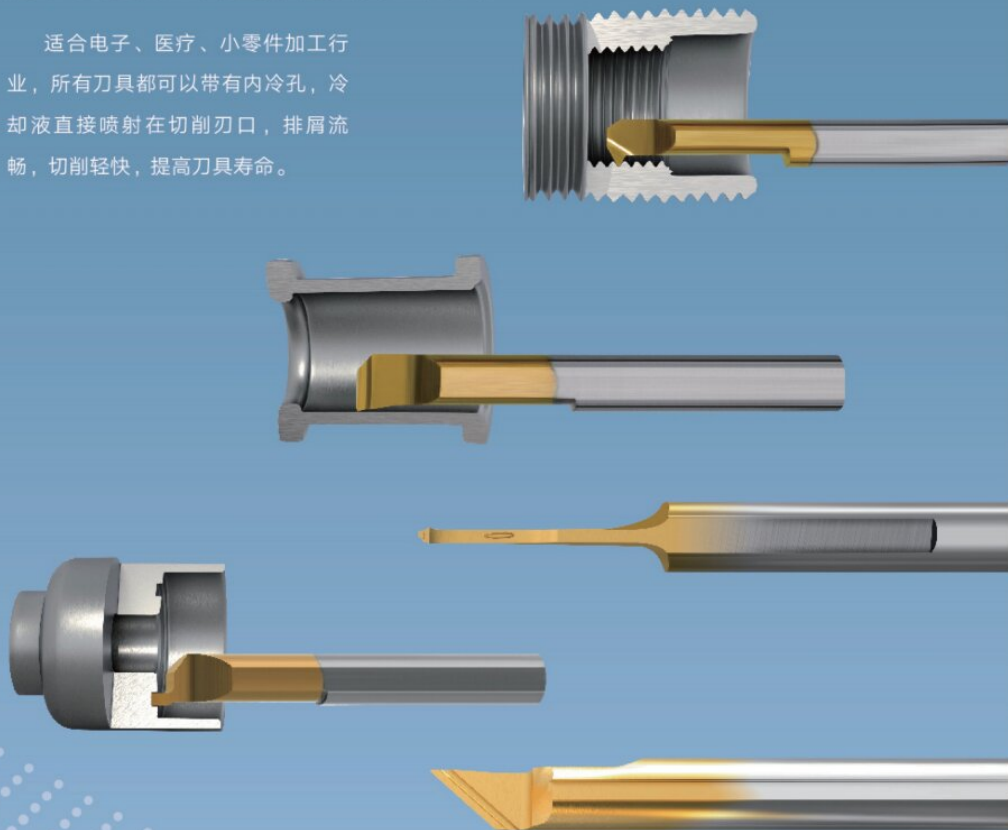

产品编号

微型镗刀

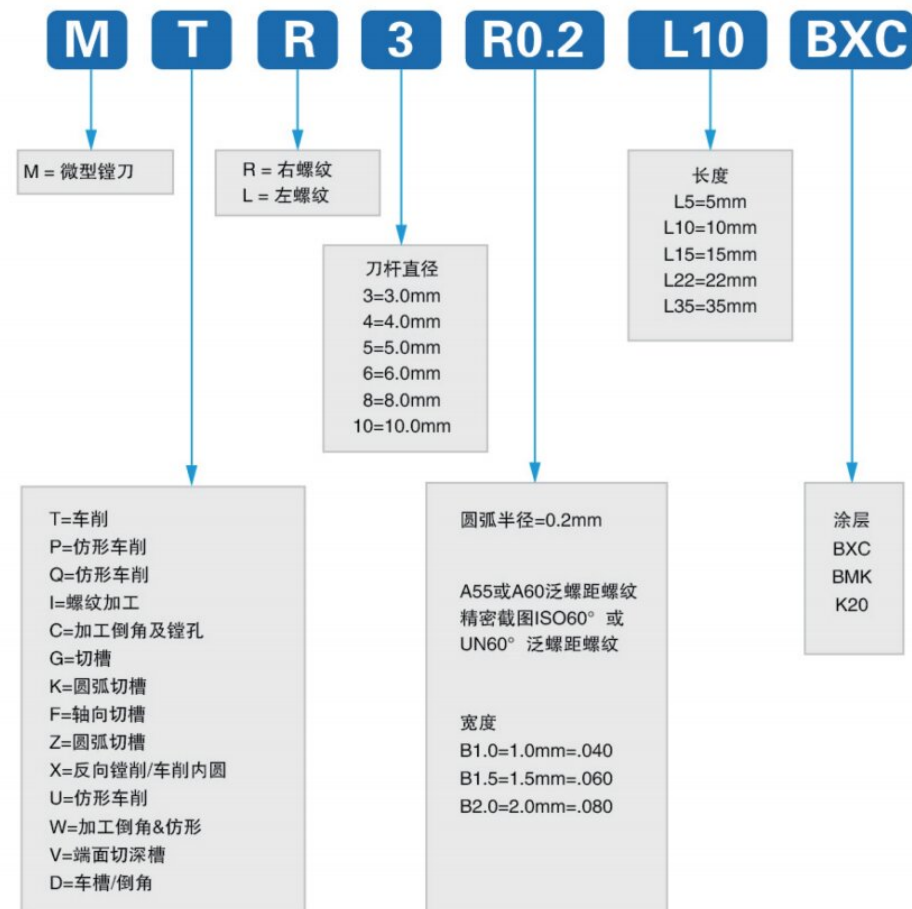

MTR微型镗刀 镗削/车削内圆

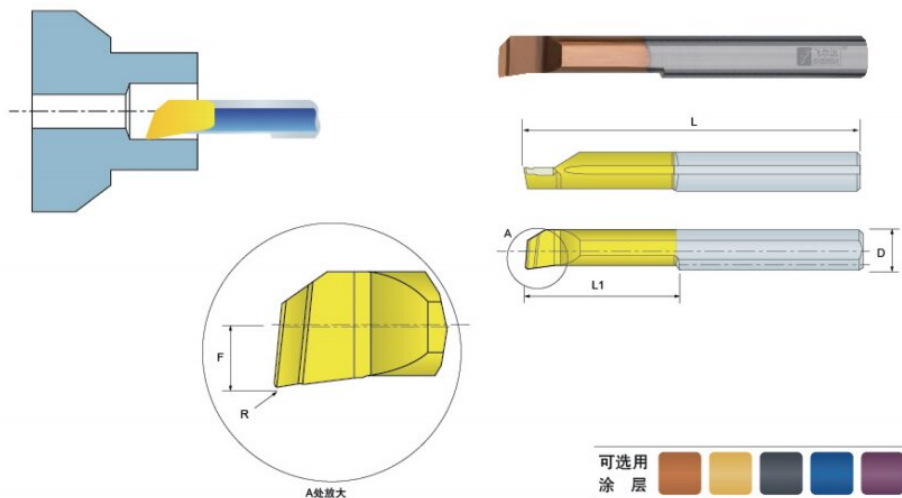

可选用
涂层

D	订货号	L	L1	R	F	最小孔径
3.0	* MTR 1 R0.05 L4	50	4	0.05	0.5	1.0
3.0	* MTR 1.5 R0.1 L6	50	6	0.10	0.7	1.5
3.0	* MTR 2 R0.05 L10	50	10	0.05	0.8	2.1
	* MTR 2 R0.15 L5	50	5	0.15	0.8	2.1
	* MTR 2 R0.15 L10	50	10	0.15	0.8	2.1
3.0	MTR 3 R0.05 L10	50	10	0.05	1.3	3.1
	MTR 3 R0.05 L15	50	15	0.05	1.3	3.1
	MTR 3 R0.1 L15	50	15	0.10	1.3	3.1
	MTR 3 R0.2 L10	50	10	0.20	1.3	3.1
	MTR 3 R0.2 L15	50	15	0.20	1.3	3.1
4.0	MTR 4 R0.05 L15	50	15	0.05	1.7	4.1
	MTR 4 R0.1 L10	50	10	0.10	1.7	4.1
	MTR 4 R0.1 L15	50	15	0.10	1.7	4.1
	MTR 4 R0.1 L22	50	22	0.10	1.7	4.1
	MTR 4 R0.2 L10	50	10	0.20	1.7	4.1
	MTR 4 R0.2 L15	50	15	0.20	1.7	4.1
	MTR 4 R0.2 L22	50	22	0.20	1.7	4.1

* 不带内冷孔

MTR微型镗刀 镗削/车削内圆

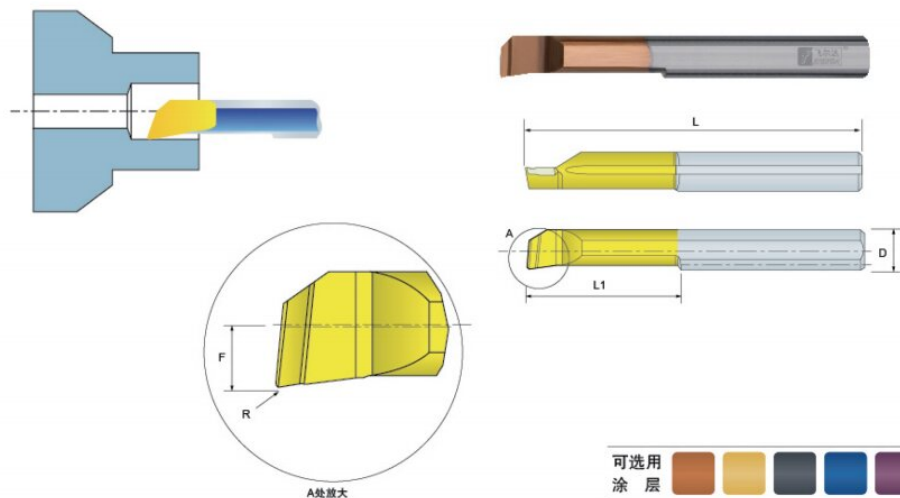

可选用
涂层

D	订货号	L	L1	R	F	最小孔径
5.0	MTR 5 R0.05 L15	50	15	0.05	2.1	5.1
	MTR 5 R0.1 L15	50	15	0.10	2.1	5.1
	MTR 5 R0.1 L22	50	22	0.10	2.1	5.1
	MTR 5 R0.1 L30	75	30	0.10	2.1	5.1
	MTR 5 R0.2 L15	50	15	0.20	2.1	5.1
	MTR 5 R0.2 L22	50	22	0.20	2.1	5.1
	MTR 5 R0.2 L30	75	30	0.20	2.1	5.1
6.0	MTR 6 R0.05 L15	50	15	0.05	2.8	6.1
	MTR 6 R0.1 L15	50	15	0.10	2.8	6.1
	MTR 6 R0.2 L15	50	15	0.20	2.8	6.1
	MTR 6 R0.2 L22	50	22	0.20	2.8	6.1
	MTR 6 R0.2 L30	75	30	0.20	2.8	6.1
7.0	MTR 7 R0.2 L22	60	22	0.20	3.3	7.1
	MTR 7 R0.2 L30	60	30	0.20	3.3	7.1
	MTR 8 R0.2 L15	60	15	0.20	3.8	8.1
8.0	MTR 8 R0.2 L22	60	22	0.20	3.8	8.1
	MTR 8 R0.2 L35	75	35	0.20	3.8	8.1
10.0	MTR 10 R0.2 L35	75	35	0.20	4.8	10.1

可定制各种非标尺寸

MXR 微型镗刀 反向镗削/车削内圆

MPR 微型镗刀 仿形车削

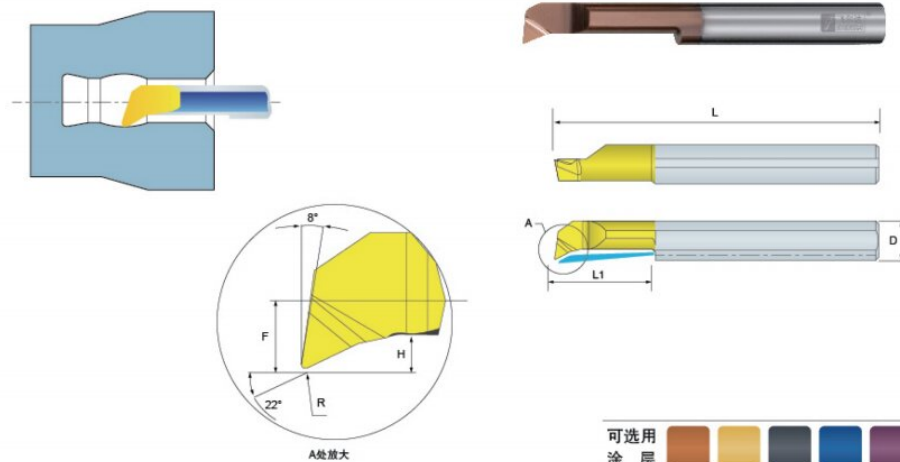
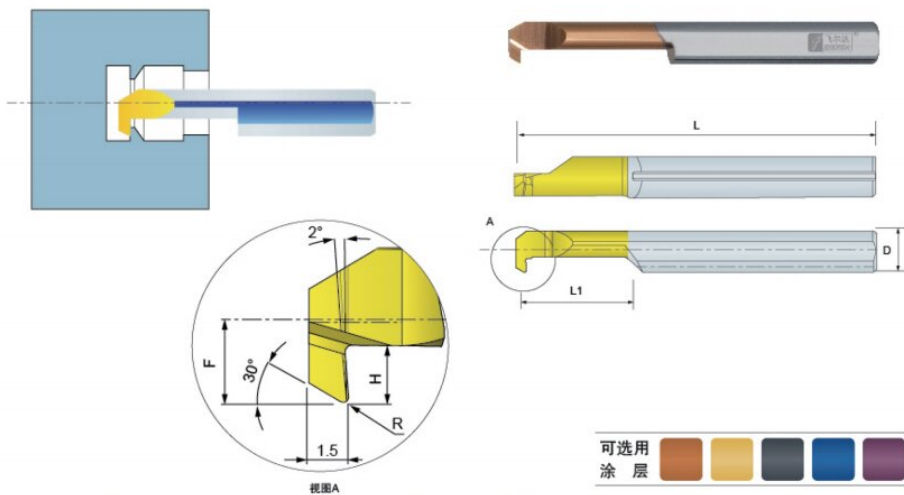

D	订货号	L	L1	R	H	F	最小孔径
4.0	MXR 4 R0.1 L10	50	10	0.10	0.5	1.3	3.1
4.0	MXR 4 R0.15 L10	50	10	0.15	0.8	1.6	4.1
4.0	MXR 4 R0.15 L15	50	15	0.15	0.8	1.6	4.1
5.0	MXR 5 R0.2 L 15	50	15	0.20	1.0	2.2	5.1
5.0	MXR 5 R0.2 L22	50	22	0.20	1.0	2.2	5.1
6.0	MXR 6 R0.2 L15	50	15	0.20	1.8	2.8	6.1
6.0	MXR 6 R0.2 L22	50	22	0.20	1.8	2.8	6.1

D	订货号	L	L1	R	H	F	最小孔径
3.0	* MPR 1 R0.05 L4	50	4	0.05	0.2	0.5	1.0
3.0	* MPR 1.5 R0.1 L6	50	6	0.10	0.3	0.7	1.5
4.0	* MPR 1.5 R0.1 L10	50	10	0.10	0.3	0.7	1.5
4.0	* MPR 2 R0.05 L10	50	10	0.05	0.5	0.8	2.1
4.0	* MPR 2 R0.1 L10	50	10	0.10	0.5	0.8	2.1
5.0	* MPR 2 R0.15 L5	50	5	0.15	0.5	0.8	2.1
5.0	* MPR 2 R0.15 L10	50	10	0.15	0.5	0.8	2.1
5.0	* MPR 2 R0.15 L15	50	15	0.15	0.5	0.8	2.1
5.0	MPR 3 R0.05 L10	50	10	0.05	0.7	1.3	3.1
5.0	MPR 3 R0.05 L15	50	15	0.05	0.7	1.3	3.1
6.0	MPR 3 R0.1 L15	50	15	0.10	0.7	1.3	3.1
6.0	MPR 3 R0.1 L22	50	22	0.10	0.7	1.3	3.1
6.0	MPR 3 R0.2 L10	50	10	0.20	0.7	1.3	3.1
7.0	MPR 3 R0.2 L15	50	15	0.20	0.7	1.3	3.1
7.0	MPR 3 R0.2 L22	50	22	0.20	0.7	1.3	3.1
7.0	MPR 4 R0.1 L15	50	15	0.10	0.8	1.7	4.1
8.0	MPR 4 R0.1 L22	50	22	0.10	0.8	1.7	4.1
8.0	MPR 4 R0.2 L10	50	10	0.20	0.8	1.7	4.1
8.0	MPR 4 R0.2 L15	50	15	0.20	0.8	1.7	4.1
10.0	MPR 4 R0.2 L22	50	22	0.20	0.8	1.7	4.1

可定制各种非标尺寸

* 不带内冷孔

MPR微型镗刀 仿形车削

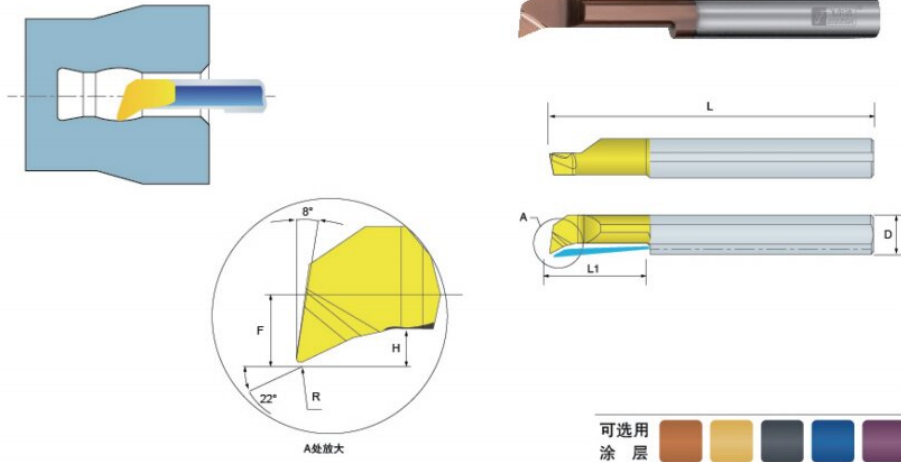

可选用
涂层

D	订货号	L	L1	R	H	F	最小孔径
5.0	MPR 5 R0.1 L22	50	22	0.10	1.2	2.1	5.1
5.0	MPR 5 R0.1 L30	75	30	0.10	1.2	2.1	5.1
5.0	MPR 5 R0.2 L15	50	15	0.20	1.2	2.1	5.1
5.0	MPR 5 R0.2 L22	50	22	0.20	1.2	2.1	5.1
5.0	MPR 5 R0.2 L30	75	30	0.20	1.2	2.1	5.1
6.0	MPR 6 R0.2 L15	50	15	0.20	1.4	2.8	6.1
6.0	MPR 6 R0.2 L22	50	22	0.20	1.4	2.8	6.1
6.0	MPR 6 R0.2 L30	75	30	0.20	1.4	2.8	6.1
7.0	MPR 7 R0.2 L22	60	22	0.20	1.5	3.3	7.1
7.0	MPR 7 R0.2 L30	60	30	0.20	1.5	3.3	7.1
7.0	MPR 7 R0.2 L35	60	35	0.20	1.5	3.3	7.1
8.0	MPR 8 R0.2 L15	60	15	0.20	1.6	3.8	8.1
8.0	MPR 8 R0.2 L22	60	22	0.20	1.6	3.8	8.1
8.0	MPR 8 R0.2 L35	75	35	0.20	1.6	3.8	8.1
10.0	MPR 10 R0.2 L35	75	35	0.20	2.0	4.8	10.1

可定制各种非标尺寸

MUR微型镗刀 仿形车削

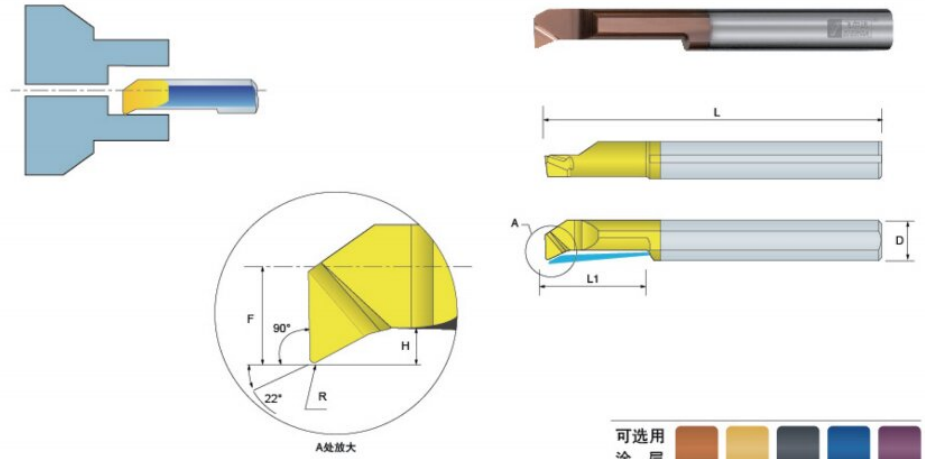

可选用
涂层

D	订货号	L	L1	R	H	F	最小孔径
3.0	MUR 3 R0.005 L10	50	10	0.05	0.4	1.3	3.1
3.0	MUR 3 R0.005 L15	50	15	0.05	0.4	1.3	3.1
4.0	MUR 4 R0.1 L10	50	10	0.10	0.5	1.7	4.1
4.0	MUR 4 R0.1 L15	50	15	0.10	0.5	1.7	4.1
5.0	MUR 5 R0.15 L22	50	15	0.15	0.7	2.1	5.1
5.0	MUR 5 R0.15 L22	50	22	0.15	0.7	2.1	5.1
6.0	MUR 6 R0.15 L15	50	15	0.15	0.9	2.8	6.1
6.0	MUR 6 R0.15 L22	50	22	0.15	0.9	2.8	6.1
8.0	MUR 8 R0.2 L22	60	22	0.20	1.1	3.8	8.1

可定制各种非标尺寸

MQR微型镗刀 仿形车削

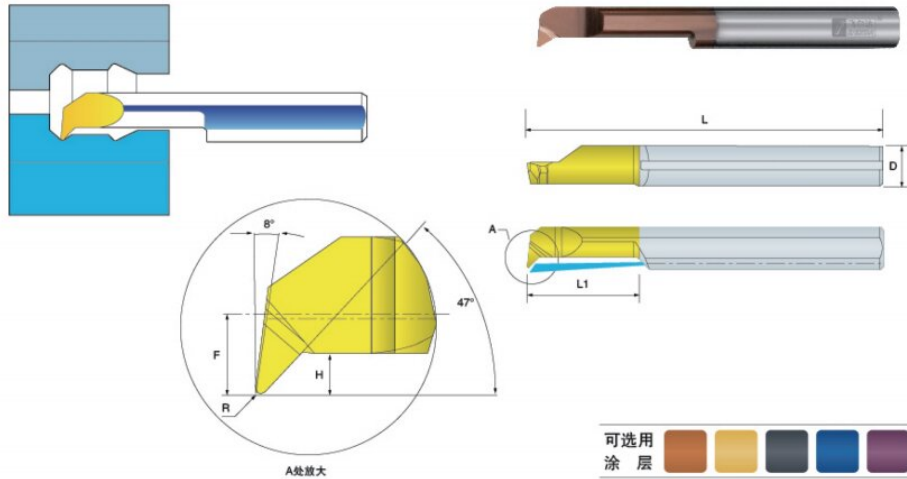

D	订货号	L	L1	R	H	F	最小孔径
4.0	MQR 4 R0.2 L10	50	10	0.20	0.8	1.8	4.1
4.0	MQR 4 R0.2 L15	50	15	0.20	0.8	1.8	4.1
4.0	MQR 4 R0.2 L22	50	22	0.20	0.8	1.8	4.1
5.0	MQR 5 R0.2 L15	50	15	0.20	1.0	2.3	5.1
5.0	MQR 5 R0.2 L22	50	22	0.20	1.0	2.3	5.1
6.0	MQR 6 R0.2 L15	50	15	0.20	1.4	2.8	6.1
6.0	MQR 6 R0.2 L22	50	22	0.20	1.4	2.8	6.1
6.0	MQR 6 R0.2 L30	75	30	0.20	1.4	2.8	6.1
8.0	MQR 8 R0.2 L22	60	22	0.20	1.6	3.8	8.1
8.0	MQR 8 R0.2 L27	60	27	0.20	2.0	3.8	8.1

可定制各种非标尺寸



MIR微型镗刀 螺纹加工

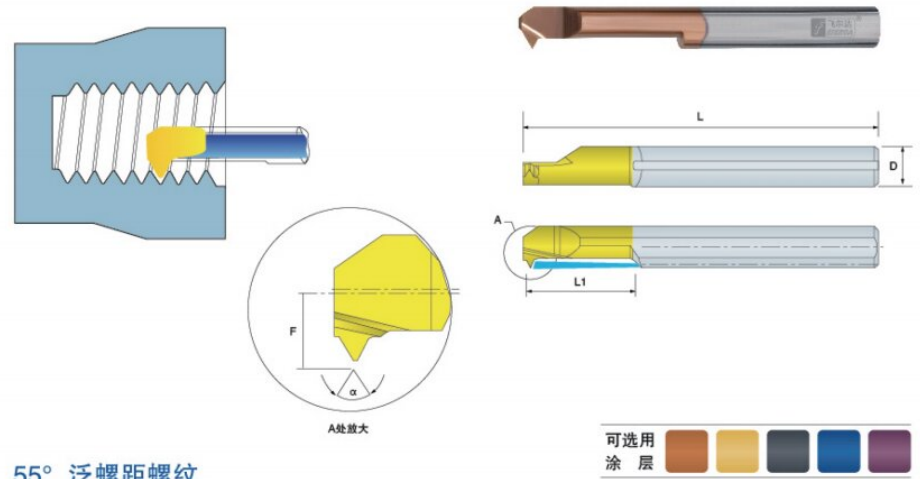

55° 泛螺距螺纹

D	订货号	L	L1	α	螺距		F	最小孔径
					mm	牙数/英寸		
3.0	MIR 3 L15 A55	50	15	55	0.5-1.0	48-24	1.4	3.2
4.0	MIR 4 L15 A55	50	15	55	0.5-1.0	48-24	1.8	4.1
5.0	MIR 5 L15 A55	50	15	55	0.5-1.25	48-20	2.3	5.1
5.0	MIR 5 L22 A55	50	22	55	0.5-1.25	48-20	2.3	5.1
6.0	MIR 6 L15 A55	50	15	55	0.5-1.5	48-16	2.6	6.0
6.0	MIR 6 L22 A55	50	22	55	0.5-1.5	48-16	2.6	6.0

可定制各种非标尺寸

60° 泛螺距螺纹

D	订货号	L	L1	α	螺距		F	最小孔径
					mm	牙数/英寸		
3.0	MIR 1 L5 A60	50	4.8	60	0.25-0.35	100-72	0.55	1.2
3.0	MIR 1 L6 A60	50	6.3	60	0.35-0.45	72-56	0.65	1.4
3.0	MIR 2 L8 A60	50	8	60	0.45-0.7	56-32	1.0	2.1
3.0	MIR 3 L15 A60	50	15	60	0.8-1.0	32-24	1.4	3.2
4.0	MIR 4 L15 A60	50	15	60	0.8-1.0	32-24	1.8	4.1
5.0	MIR 5 L15 A60	50	15	60	1.0-1.25	24-20	2.3	5.1
5.0	MIR 5 L22 A60	50	22	60	1.0-1.25	24-20	2.3	5.1
6.0	MIR 6 L15 A60	50	15	60	1.0-1.5	24-16	2.6	6.0
6.0	MIR 6 L22 A60	50	22	60	1.0-1.5	24-16	2.6	6.0
8.0	MIR 8 L22 A60	60	22	60	1.0-2.0	24-13	3.6	8.0

可定制各种非标尺寸

MIR微型镗刀 螺纹加工

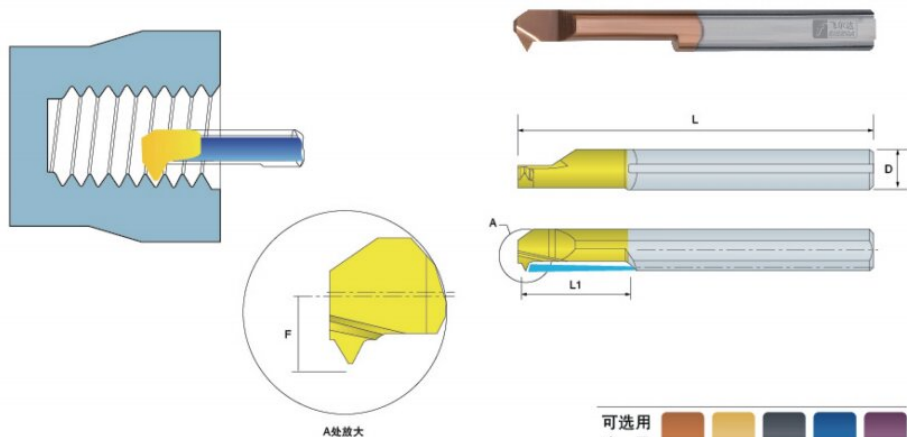

60° 定螺距螺纹-ISO

D	订货号	螺距 mm	L	L1	F	最小孔径
3.0	MIR 3 L15 0.5 ISO	M4 × 0.5	50	15	1.4	3.2
3.0	MIR 3 L15 0.7 ISO	M4 × 0.7	50	15	1.4	3.2
3.0	MIR 3 L15 0.75 ISO	M4.5 × 0.75	50	15	1.4	3.2
4.0	MIR 4 L15 0.5 ISO	M5 × 0.5	50	15	1.8	4.1
4.0	MIR 4 L15 0.75 ISO	M5 × 0.75	50	15	1.8	4.1
4.0	MIR 4 L15 0.8 ISO	M5 × 0.8	50	15	1.8	4.1
5.0	MIR 5 L15 1.0 ISO	M6 × 1.0	50	15	2.2	4.9
6.0	MIR 6 L22 1.25 ISO	M8 × 1.25	50	22	2.8	6.1

可定制各种非标尺寸

60° 定螺距螺纹-UN

D	订货号	螺距 mm	L	L1	F	最小孔径
3.0	MIR 3 L15 36 UN	8-36UNF	50	15	1.4	3.2
3.0	MIR 3 L15 32 UN	8-32UNC	50	15	1.4	3.2
4.0	MIR 4 L15 36 UN	12-36UNS	50	15	1.8	4.1
4.0	MIR 4 L15 32 UN	12-32UNEF	50	15	1.8	4.1
5.0	MIR 5 L15 28 UN	1/4-28UNF	50	15	2.2	4.9
5.0	MIR 5 L18 20 UN	1/4-20UNC	50	18	2.3	5.0
6.0	MIR 6 L18 24 UN	5/16-24UNF	50	18	2.8	6.5
6.0	MIR 6 L18 18 UN	5/16-18UNC	50	18	2.8	6.2

可定制各种非标尺寸

MIR微型镗刀 螺纹加工

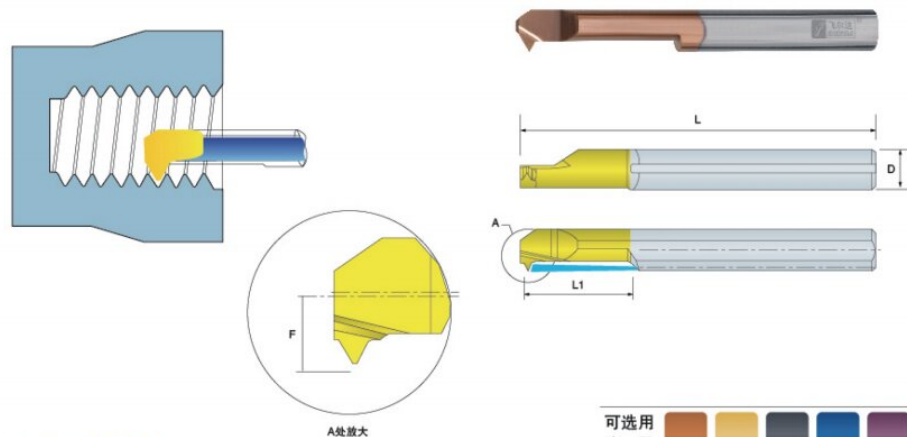

NPT锥管螺纹

D	订货号	螺距 牙数/英寸	L	L1	F	最小孔径	螺纹
6.0	MIR 6 L15 27 NPT	27	50	15	2.6	5.9	1/16 × 27NPT 1/8 × 27NPT

可定制各种非标尺寸



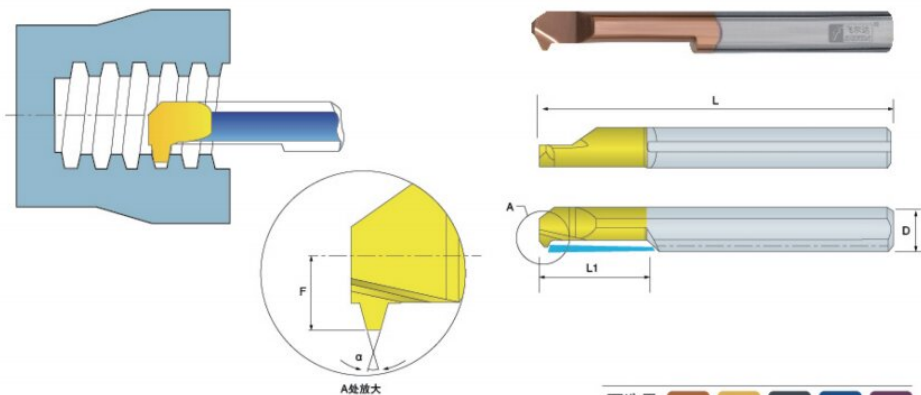

Acme 梯形螺纹

D	订货号	螺距 牙数/英寸	L	L1	F	α	最小孔径	螺纹
4.0	MIR 4 L15 16 ACME	16	50	15	1.8	29	4.6	1/4 × 16
6.0	MIR 6 L20 14 ACME	14	50	20	2.8	29	6.0	5/16 × 14
7.0	MIR 7 L22 12 ACME	12	60	22	3.3	29	7.2	3/8 × 12
8.0	MIR 8 L30 10 ACME	10	75	30	3.8	29	10.0	1/2 × 10
10.0	MIR 10 L35 8 ACME	8	75	35	4.8	29	12.5	5/8 × 8
10.0	MIR 10 L45 6 ACME	6	100	45	4.8	29	14.6	3/4 × 6 7/8 × 6

可定制各种非标尺寸

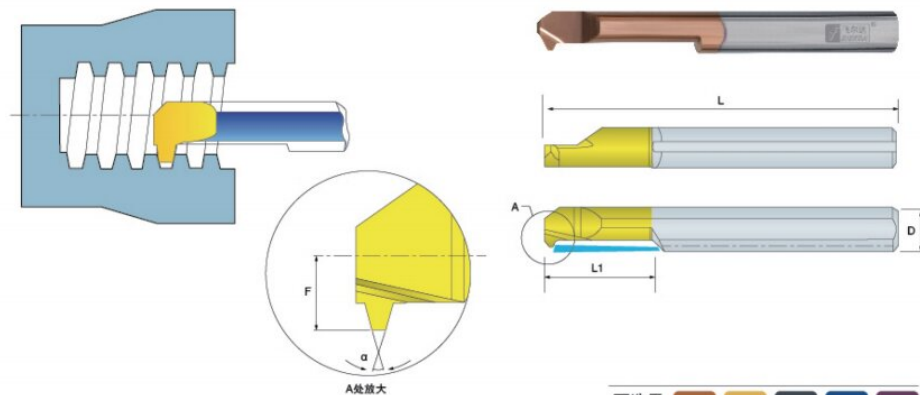
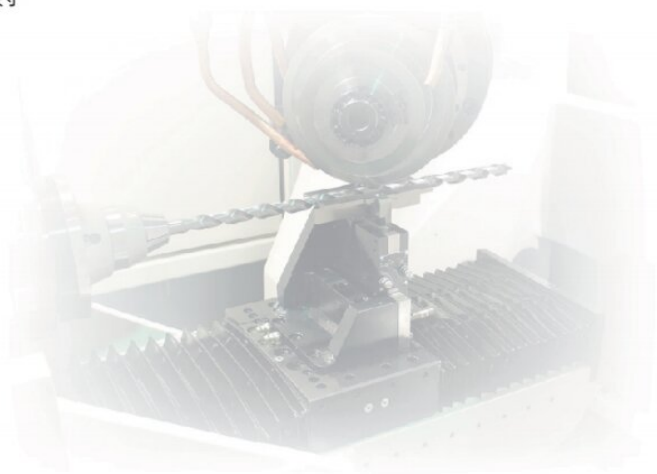

D	订货号	螺距 牙数/英寸	L	L1	F	α	最小孔径	螺纹
7.0	MIR 7 L25 2 TR	2	60	25	3.2	30	6.9	Tr 9 × 2 Tr 10 × 2 Tr 11 × 2 Tr 12 × 2
10.0	MIR 10 L35 2 TR	2	75	35	4.8	30	11.0	Tr 14 × 2 Tr 16 × 2 Tr 18 × 2 Tr 20 × 2
7.0	MIR 7 L35 3 TR	3	60	35	3.3	30	7.5	Tr 11 × 3 Tr 12 × 3
10.0	MIR 10 L35 3 TR	3	75	35	4.8	30	10.5	Tr 14 × 3 Tr 22 × 3 Tr 24 × 3 Tr 26 × 3 Tr 28 × 3
10.0	MIR 10 L45 4 TR	4	100	45	4.8	30	11.5	Tr 16 × 4 Tr 18 × 4 Tr 20 × 4
10.0	MIR 10 L55 5 TR	5	100	55	4.8	30	11.0	Tr 22 × 5 Tr 24 × 5 Tr 28 × 5

可定制各种非标尺寸

MDR微型镗刀 车削 倒角 切槽

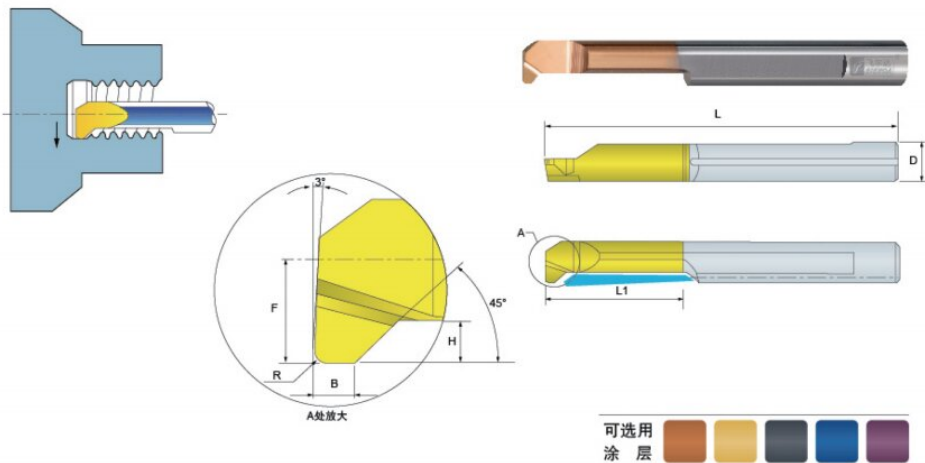

可选项
涂层

D	订货号	L	L1	B	R	H	F	最小孔径
4.0	MDR 4 R0.5 L18	50	18	1.5	0.5	0.8	1.8	4.1
5.0	MDR 5 R0.5 L24	50	24	1.5	0.5	1.2	2.3	5.1
6.0	MDR 6 R0.5 L27	75	27	1.5	0.5	1.4	2.8	6.1

可定制各种非标尺寸

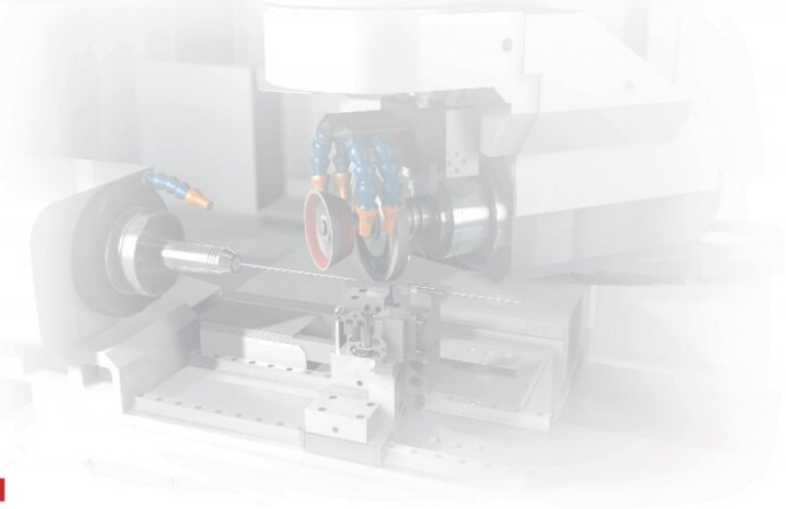

MCR微型镗刀 加工倒角及镗孔

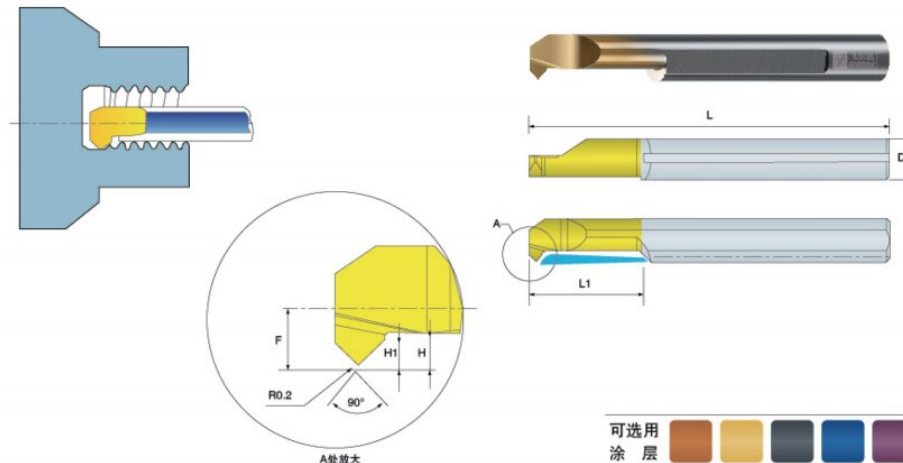

可选项
涂层

D	订货号	L	L1	R	H	H1	F	最小孔径
3.0	MCR 3 R0.2 L10	50	10	0.20	0.7	0.3	1.3	3.1
4.0	MCR 4 R0.2 L15	50	15	0.20	0.8	0.4	1.7	4.1
5.0	MCR 5 R0.2 L15	50	15	0.20	1.2	0.7	2.1	5.1
6.0	MCR 6 R0.2 L15	50	15	0.20	1.4	0.7	2.8	6.1
7.0	MCR 7 R0.2 L20	60	20	0.20	1.5	0.8	3.3	7.1

可定制各种非标尺寸



MWR微型镗刀 加工倒角/仿形

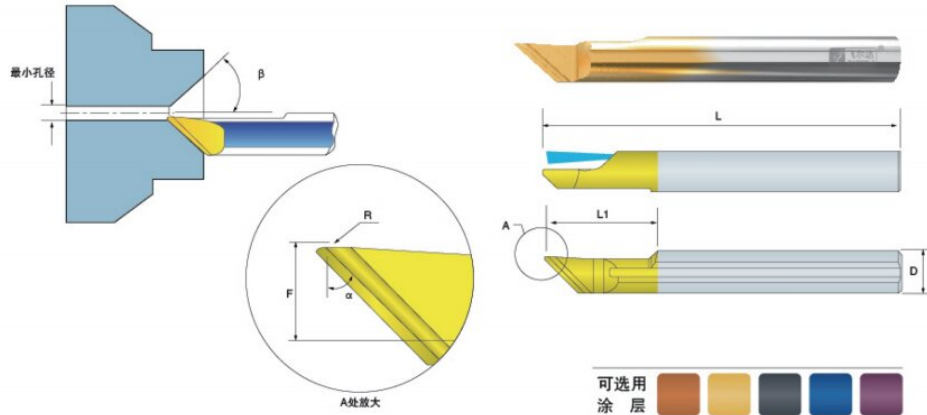

D	订货号	L	L1	R	α	β	F	最小孔径
6.0	MWR 6 R0.2 A90	50	15.0	0.20	45°	45°	2.3	1.0
6.0	MWR 6 R0.2 A60	50	15.0	0.20	60°	30°	2.3	1.0

可定制各种非标尺寸

MWL

D	订货号	L	L1	R	α	β	F	最小孔径
6.0	MWL 6 R0.2 A90	50	15.0	0.20	45°	45°	2.3	1.0
6.0	MWL 6 R0.2 A60	50	15.0	0.20	60°	30°	2.3	1.0

可定制各种非标尺寸

MGR微型镗刀 切槽

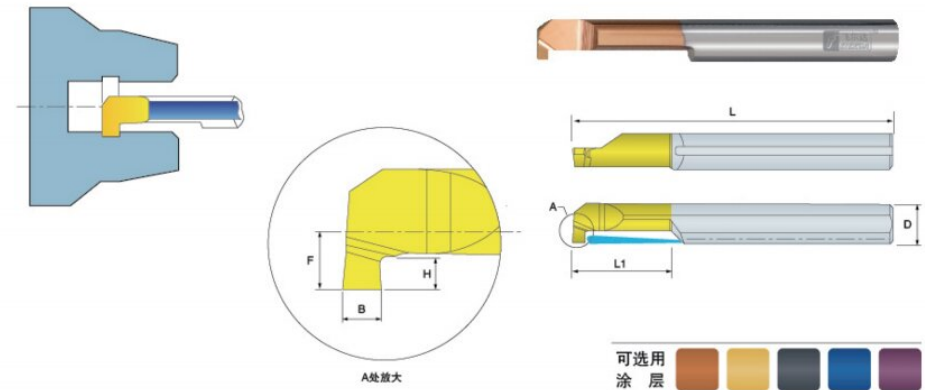

D	订货号	L	L1	B	H	F	最小孔径
3.0	MGR 3 B0.7 L10	50	10	0.7	0.6	1.3	3.1
4.0	MGR 4 B1.0 L10	50	10	1.0	1.0	1.7	4.1
4.0	MGR 4 B1.0 L15	50	15	1.0	1.0	1.7	4.1
4.0	MGR 4 B1.5 L10	50	10	1.5	1.0	1.7	4.1
5.0	MGR 5 B1.0 L15	50	15	1.0	1.2	2.3	5.1
5.0	MGR 5 B1.0 L22	50	22	1.0	1.2	2.3	5.1
5.0	MGR 5 B1.5 L15	50	15	1.5	1.2	2.3	5.1
5.0	MGR 5 B1.5 L22	50	22	1.5	1.2	2.3	5.1
5.0	MGR 5 B2.0 L15	50	15	2.0	1.2	2.3	5.1
5.0	MGR 5 B2.0 L22	50	22	2.0	1.2	2.3	5.1
6.0	MGR 6 B1.0 L15	50	15	1.0	1.4	2.8	6.1
6.0	MGR 6 B1.0 L22	50	22	1.0	1.4	2.8	6.1
6.0	MGR 6 B1.5 L15	50	15	1.5	1.4	2.8	6.1
6.0	MGR 6 B1.5 L22	50	22	1.5	1.4	2.8	6.1
6.0	MGR 6 B2.0 L15	50	15	2.0	1.4	2.8	6.1
6.0	MGR 6 B2.0 L22	50	22	2.0	1.4	2.8	6.1
7.0	MGR 7 B1.0 L15	60	15	1.0	2.5	3.3	7.1
7.0	MGR 7 B1.0 L22	60	22	1.0	2.5	3.3	7.1
7.0	MGR 7 B1.0 L30	60	30	1.0	2.5	3.3	7.1
7.0	MGR 7 B1.5 L15	60	15	1.5	2.5	3.3	7.1
7.0	MGR 7 B1.5 L22	60	22	1.5	2.5	3.3	7.1
7.0	MGR 7 B1.5 L30	60	30	1.5	2.5	3.3	7.1
7.0	MGR 7 B2.0 L15	60	15	2.0	2.5	3.3	7.1
7.0	MGR 7 B2.0 L22	60	22	2.0	2.5	3.3	7.1
7.0	MGR 7 B2.0 L30	60	30	2.0	2.5	3.3	7.1
8.0	MGR 8 B1.0 L22	60	22	1.0	1.7	3.8	8.1
8.0	MGR 8 B1.5 L22	60	22	1.5	1.7	3.8	8.1
8.0	MGR 8 B2.0 L22	60	22	2.0	2.6	3.8	8.1

可定制各种非标尺寸

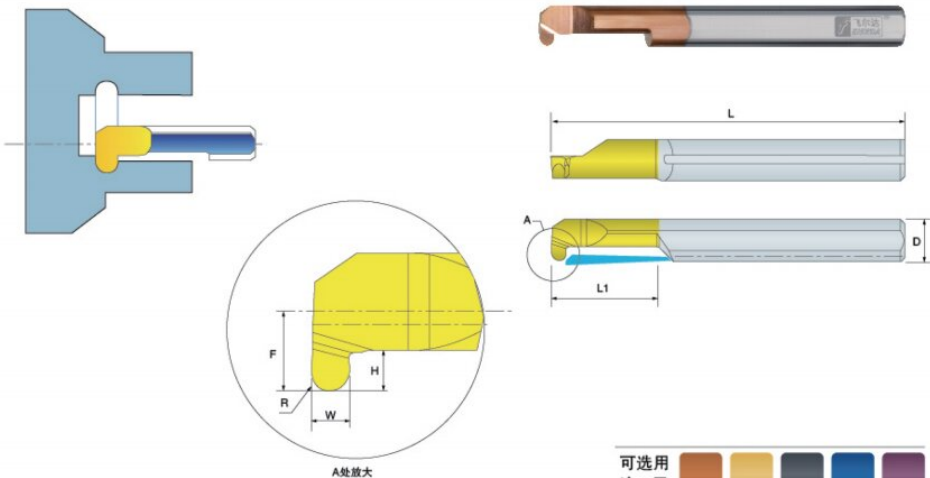

D	订货号	L	L1	R	W	H	F	最小孔径
4.0	MKR 4 R0.5 L10	50	10	0.50	1.0	1.0	1.7	4.1
4.0	MKR 4 R0.75 L10	50	10	0.75	1.5	1.0	1.7	4.1
5.0	MKR 5 R0.5 L15	50	15	0.50	1.0	1.2	2.3	5.1
5.0	MKR 5 R0.75 L15	50	15	0.75	1.5	1.2	2.3	5.1
5.0	MKR 5 R1.0 L15	50	15	1.00	2.0	1.2	2.3	5.1
6.0	MKR 6 R0.5 L15	50	15	0.50	1.0	1.6	2.8	6.1
6.0	MKR 6 R0.75 L15	50	15	0.75	1.5	1.6	2.8	6.1
6.0	MKR 6 R1.0 L15	50	15	1.00	2.0	1.6	2.8	6.1

可定制各种非标尺寸

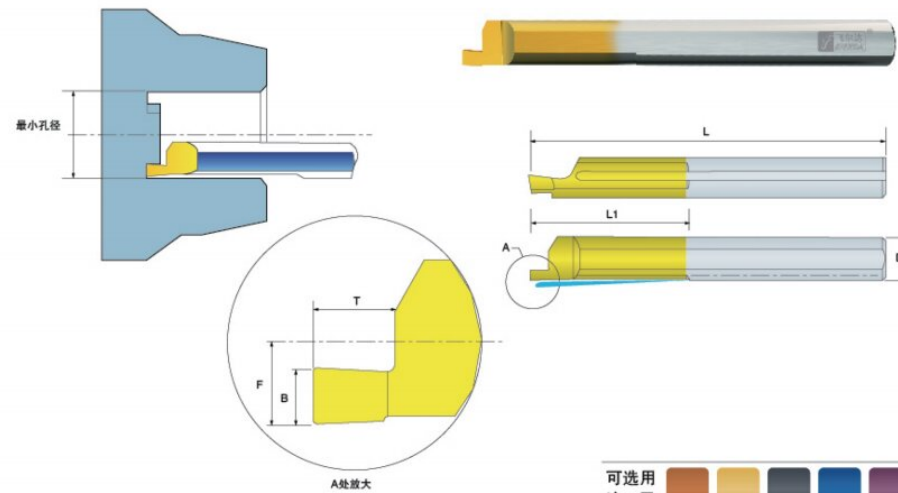

D	订货号	L	L1	B	T	F	最小孔径
4.0	MFR 4 B0.75 L15	50	15	0.75	1.2	1.95	5.0
4.0	MFR 4 B1.0 L15	50	15	1.0	1.5	1.95	5.0
4.0	MFR 4 B1.5 L15	50	15	1.5	2.8	1.95	5.0
5.0	MFR 5 B0.75 L22	50	22	0.75	1.2	2.45	6.0
5.0	MFR 5 B1.0 L22	50	22	1.0	1.5	2.45	6.0
5.0	MFR 5 B1.5 L22	50	22	1.5	2.5	2.45	6.0
5.0	MFR 5 B2.0 L22	50	22	2.0	3.8	2.45	6.0
6.0	MFR 6 B1.0 L22	50	22	1.0	1.5	2.95	8.0
6.0	MFR 6 B1.5 L22	50	22	1.5	2.5	2.95	8.0
6.0	MFR 6 B2.0 L22	50	22	2.0	3.0	2.95	8.0
6.0	MFR 6 B2.5 L22	50	22	2.5	4.8	2.95	8.0
6.0	MFR 6 B3.0 L30	75	30	3.0	6.0	2.95	8.0
8.0	MFR 8 B2.5 L22	60	22	2.5	3.5	3.95	10.0

可定制各种非标尺寸

MFL 微型镗刀 轴向切槽

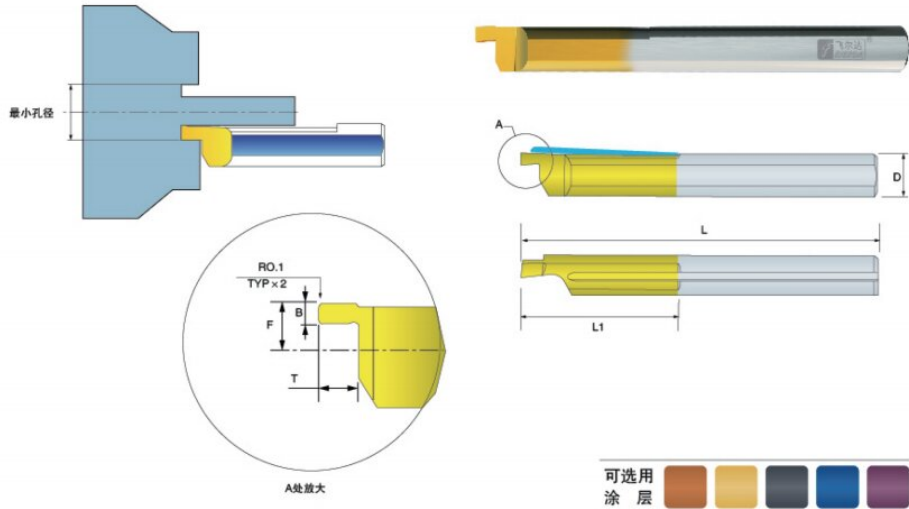

D	订货号	L	L1	B	T	F	最小孔径
4.0	MFL 4 B0.75 L15	50	15	0.75	1.2	1.75	5.0
4.0	MFL 4 B1.0 L15	50	15	1.0	1.5	1.75	5.0
4.0	MFL 4 B1.5 L15	50	15	1.5	2.8	1.75	5.0
5.0	MFL 5 B0.75 L22	50	22	0.75	1.2	2.25	6.0
5.0	MFL 5 B1.0 L22	50	22	1.0	1.5	2.25	6.0
5.0	MFL 5 B1.5 L22	50	22	1.5	2.5	2.25	6.0
5.0	MFL 5 B2.0 L22	50	22	2.0	3.8	2.25	6.0
6.0	MFL 6 B1.0 L22	50	22	1.0	1.5	2.75	8.0
6.0	MFL 6 B1.5 L22	50	22	1.5	2.5	2.75	8.0
6.0	MFL 6 B2.0 L22	50	22	2.0	3.0	2.75	8.0
6.0	MFL 6 B2.5 L22	50	22	2.5	4.8	2.75	8.0
6.0	MFL 6 B3.0 L30	75	30	3.0	6.0	2.75	8.0
8.0	MFL 8 B2.5 L22	60	22	2.5	3.5	3.75	10.0

可定制各种非标尺寸

MVR 微型镗刀 端面切深槽

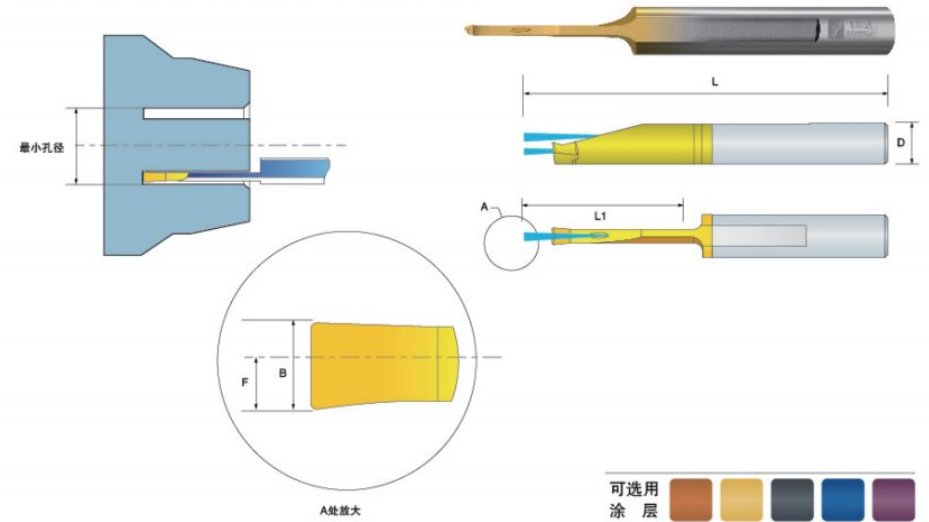

D	订货号	L	L1	B	F	最小孔径
6.0	MVR 6 B2.0 L15	64	15	2.0	1.1	12.0
6.0	MVR 6 B2.0 L22	64	22	2.0	1.1	12.0
6.0	MVR 6 B2.5 L22	64	22	2.5	1.4	12.0
8.0	MVR 8 B3.0 L27	64	27	3.0	1.6	15.0
8.0	MVR 8 B3.0 L43	80	43	3.0	1.6	15.0
8.0	MVR 8 B4.0 L43	80	43	4.0	2.1	20.0

可定制各种非标尺寸

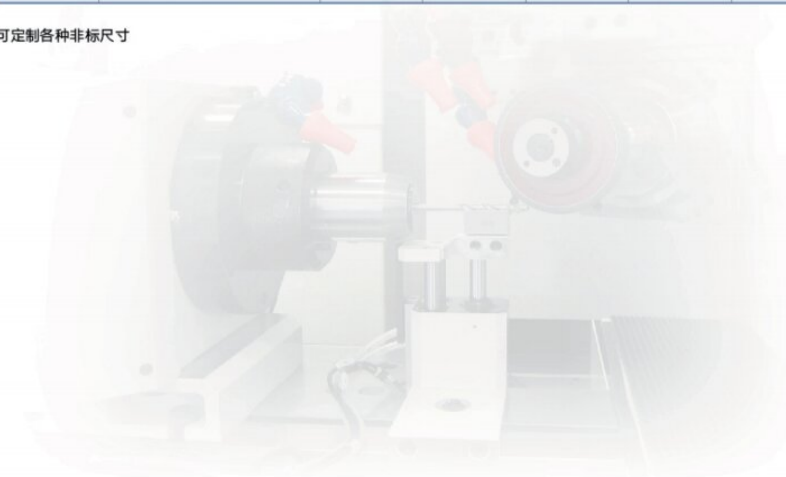

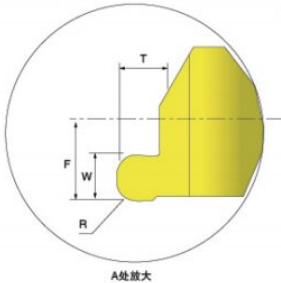
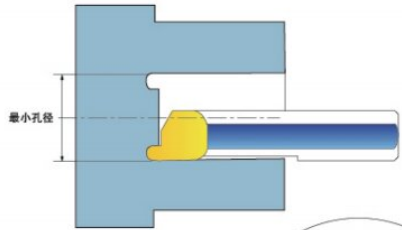

A处放大

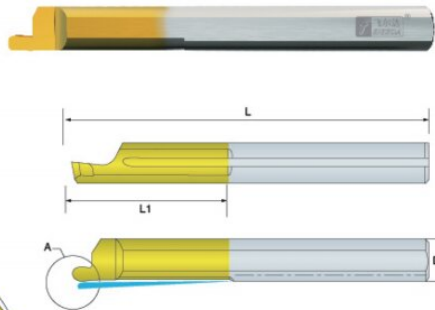

D	订货号	L	L1	R	W	T	F	最小孔径
4.0	MZR 4 R0.5 L15	50	15	0.50	1.0	1.2	1.95	5.0
4.0	MZR 4 R0.75 L15	50	15	0.75	1.5	1.5	1.95	5.0
5.0	MZR 5 R0.5 L22	50	22	0.50	1.0	1.2	2.45	6.0
5.0	MZR 5 R0.75 L22	50	22	0.75	1.5	1.5	2.45	6.0
5.0	MZR 5 R1.0 L22	50	22	1.00	2.0	2.5	2.45	6.0
6.0	MZR 6 R0.5 L22	50	22	0.50	1.0	1.2	2.95	8.0
6.0	MZR 6 R0.75 L22	50	22	0.75	1.5	1.5	2.95	8.0
6.0	MZR 6 R1.0 L22	50	22	1.00	2.0	2.5	2.95	8.0

可定制各种非标尺寸

微型镗刀刀杆

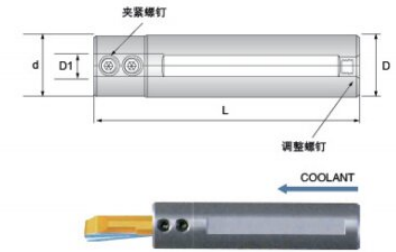

D1	订货号	L	D	d	Torx 扳手	夹紧螺钉	调整螺钉
3.0	SIM0012 H3	88	12	12	K25	S25	S35
3.0	* SIM0016 H3S	75	16	20	K25	S25	S35S
3.0	SIM0016 H3	88	16	20	K25	S25	S35
3.0	SIM0020 H3	88	20	20	K25	S25	S35
3.0	* SIM0022 H3	88	22	22	K25	S25	S35
3.0	SIM0025 H3	62	25	10.8	K25	S25	S35
4.0	SIM0012 H4	88	12	12	K25	S25	S35S
4.0	* SIM0016 H4S	75	16	20	K25	S25	S35
4.0	SIM0016 H4	88	16	20	K25	S25	S35
4.0	SIM0020 H4	88	20	20	K25	S25	S35
4.0	* SIM0022 H4	88	22	22	K25	S25	S35
4.0	SIM0025 H4	62	25	10.8	K25	S25	S35S
5.0	SIM0012 H5	88	12	12	K25	S25	S35
5.0	* SIM0016 H5S	75	16	20	K25	S25	S35
5.0	SIM0016 H5	88	16	20	K25	S25	S35
5.0	SIM0020 H5	88	20	20	K25	S25	S35S
5.0	* SIM0022 H5	75	22	22	K25	S25	S35
5.0	SIM0025 H5	62	25	10.8	K25	S25	S35
6.0	* SIM0016 H6S	75	16	20	K25	S25	S35
6.0	SIM0016 H6	88	16	20	K25	S25	S35
6.0	SIM0020 H6	88	20	20	K25	S25	S35
6.0	* SIM0022 H6	88	22	22	K25	S25	S35
6.0	SIM0025 H6	62	25	10.8	K25	S25	S35
7.0	SIM0016 H7	88	16	20	K25	S25	S35
7.0	SIM0020 H7	88	20	20	K25	S25	S35
8.0	SIM0016 H8	88	16	20	K25	S25	S35
8.0	SIM0020 H8	88	20	20	K25	S25	S35
10.0	SIM0020 H10	88	20	20	K25	S25	S35

*可同时运用于瑞士自动车床